

TR57 GENERAL ASSEMBLY

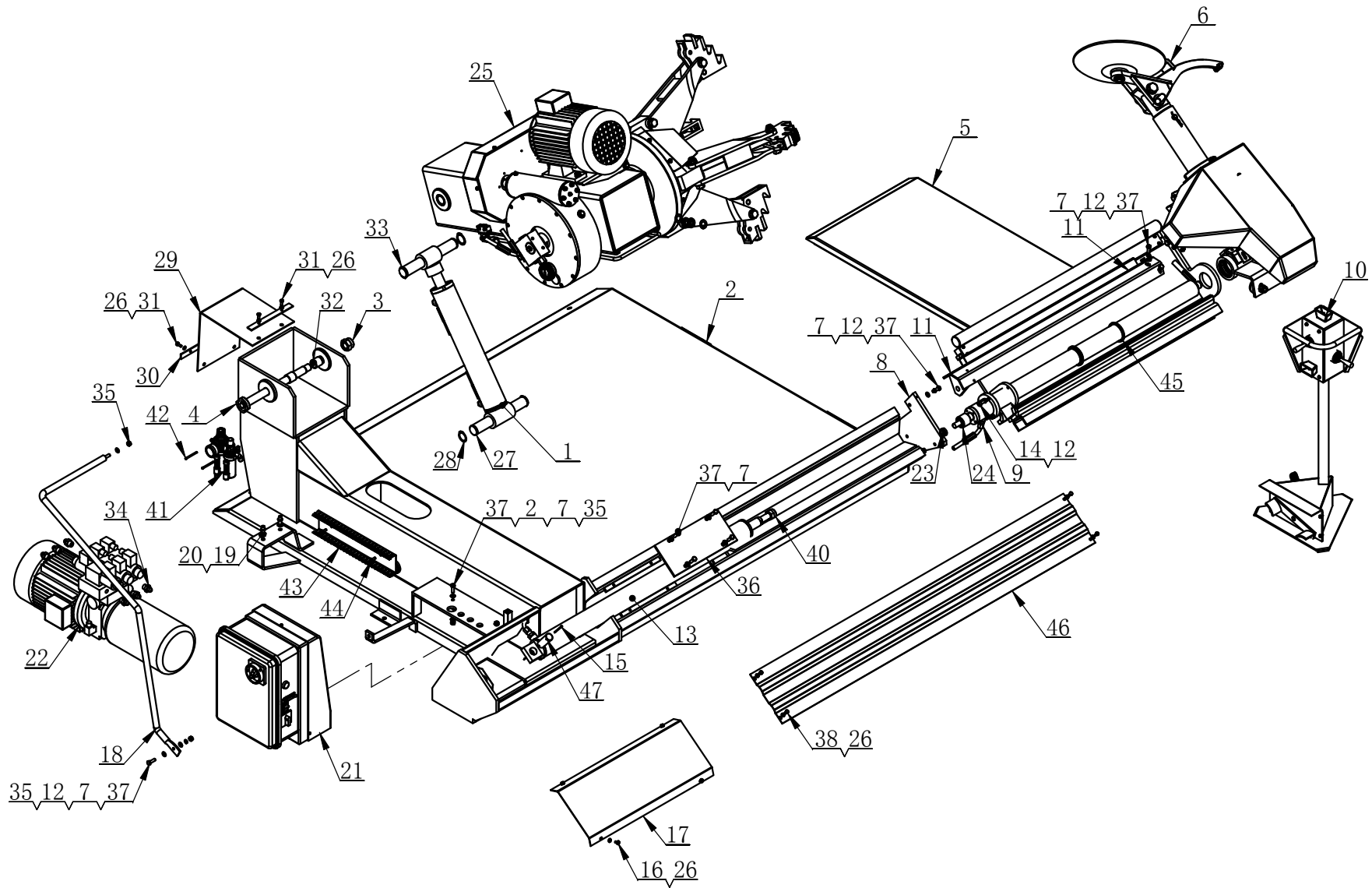

TR57.00.00.00.00

TR57 GENERAL ASSEMBLY

ITEM	PART №	Description.	QTY
1	6001503	LIFTING OIL TANK	1
2	6001515	BODY	1
3	5000049	NUT M24	1
4	6001583	LIFTING ARM ROTATION SHAFT	1
5	6003208	MAIN TRAILER	1
6	6001666	SUPPORT ARM	1
7	5000018	WASHER 8	18
8	6001728	RETAINING PLATE	1
9	6001729	BRACKET OIL TANK	1
10	6001761	OPERATION DESK	1
11	6001793	GUARD BAR	1
12	5004046	WASHER 8	12
13	6001799	TRAILER OIL TANK	1
14	5004060	SCREW M8X30	3
15	5000116	PIN 3.2X32	2
16	5000117	SCREW M6X12	4
17	6001811	PROTECTIVE PLATE B	1
18	6001813	PROTECTIVE BRACKET	1
19	5000022	BOLT M10X30	2
20	5010006	WASHER 10	2
21	6001815	AIR CONTROLING ASSEMBLY	1
22	5500093	HYDRAULIC PUMP	1
23	5000105	NUT M16	1
24	6001823	NYLON COVER	1
25	6003207	LIFTING ARM ASSEMBLY	1
26	5000007	WASHER 6	12
27	6001824	FIXTURE SHAFT	2
28	5000097	CRICLIP 32	2
29	6001592	RUBBER PLATE	1
30	6001593	PRESS PLATE	2
31	5000057	BOLT M6X16	4
32	6001595	COPPER BUSHING	2
33	5006411	RING 35	2
34	6001738	DOUBLE SCREW	8
35	5002060	NUT M8	4
36	6001598	RETAINING PLATE	1
37	5000019	BOLT M8X25	13
38	5004248	BOLT M6X12	4
39	5004249	WASHER 20	1
40	5004250	NUT M20X1.5	1
41	5502035	AIR REGULATOR ASSY	1
42	5002041	SCREW M4X50	2
43	5500044	SHORT WIRE GROOVE 25X30	1
44	5002010	SCREW M6X16	3
45	5500082	DUSTPROOF WASHER 60-80	2
46	6001798	PROTECTIVE PLATE	1
47	6001810	FIXTURE PIN SHAFT	1

6003207 VERTICAL MOVABLE ARM

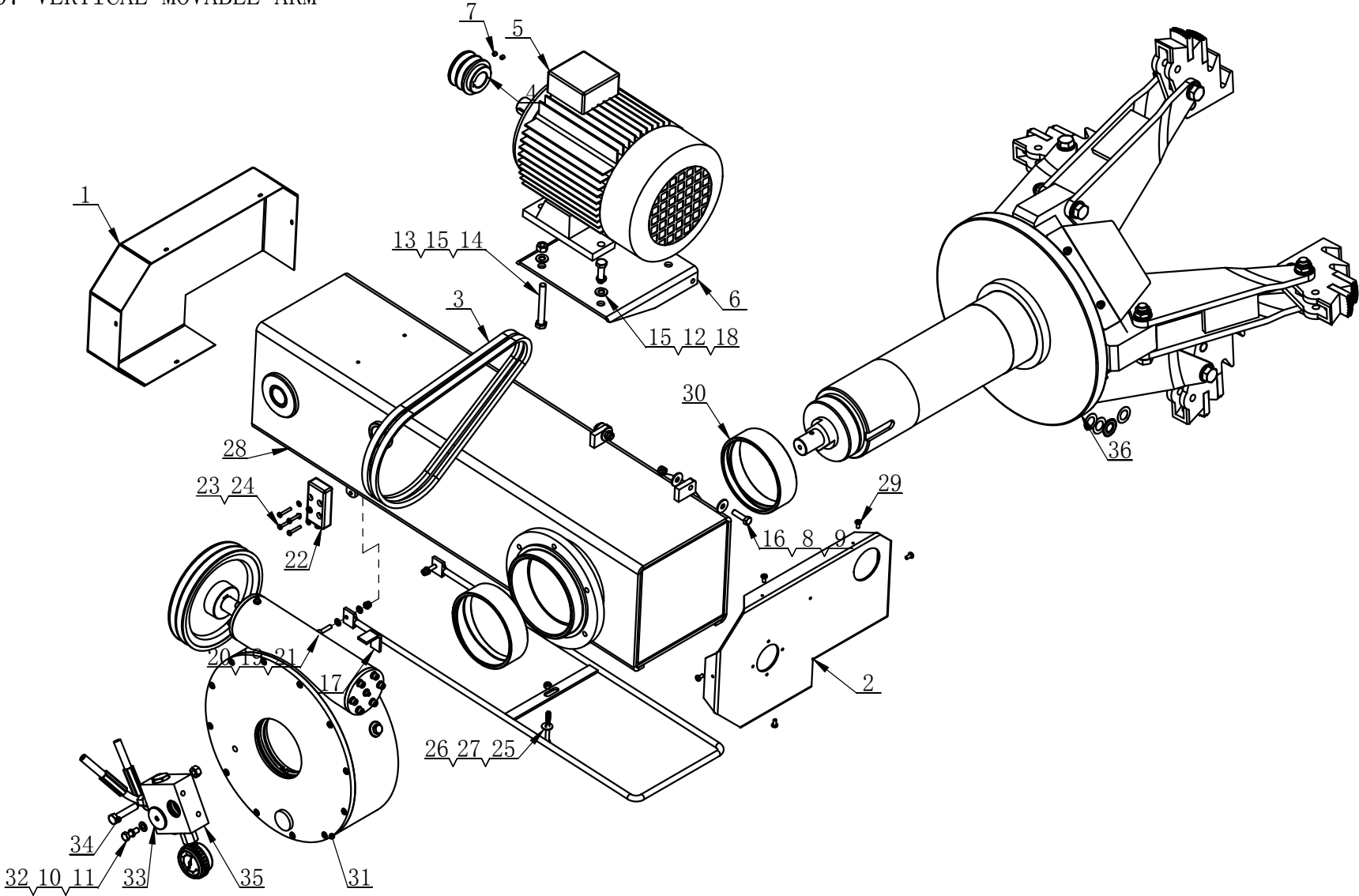

6003207 VERTICAL MOVABLE ARM

ITEM	PART №	Description.	QTY
1	6001614	PROTECTIVE COVER	1
2	6001613	MOTOR BOTTOM COVER	1
3	5500094	BELT A850	2
4	6001615	SMALL BELT PULLEY	1
5	5500092	MOTOR	1
6	6001612	MOTOR BASE PLATE	1
7	5000099	SCREW M6X10	2
8	5010081	WASHER 8	6
9	5010092	NUT M8	2
10	5004046	WASHER 8	3
11	5000107	BOLT M8X25	3
12	5000063	BOLT M10X35	3
13	5010004	NUT M10	2
14	5004244	SCREW M6X80	1
15	5004041	WASHER 10	4
16	5000093	BOLT M8X30	2
17	6001596	BRACKET	1
18	5010006	WASHER 10	3
19	5000007	WASHER 6	4
20	5004047	NUT M6	2
21	5006006	SCREW M6X25	2
22	5508009	STROLE SWITCH	1
23	5010040	WASHER 4	4
24	5000134	NUT M4X25	4
25	5006077	WASHER 6	1
26	5004008	NUT M6	1
27	5004244	HSHCS M6X80	1
28	6001586	LIFTING ARM	1
29	5006439	SCREW M5X10	5
30	6001594	BIG COPPER BUSHING	2
31	6001569	GEARBOX ASSEMBLY	1
32	5000018	WASHER 8	1
33	6001555	PRESS COVER	1
34	5000115	BOLT M10x50	1
35	5500091	OIL GUIDER VALVE BODY	1
36	6001616	CLAMP OIL TANK	1

60031616 PRINCIPAL AXIS ASSEMBLY

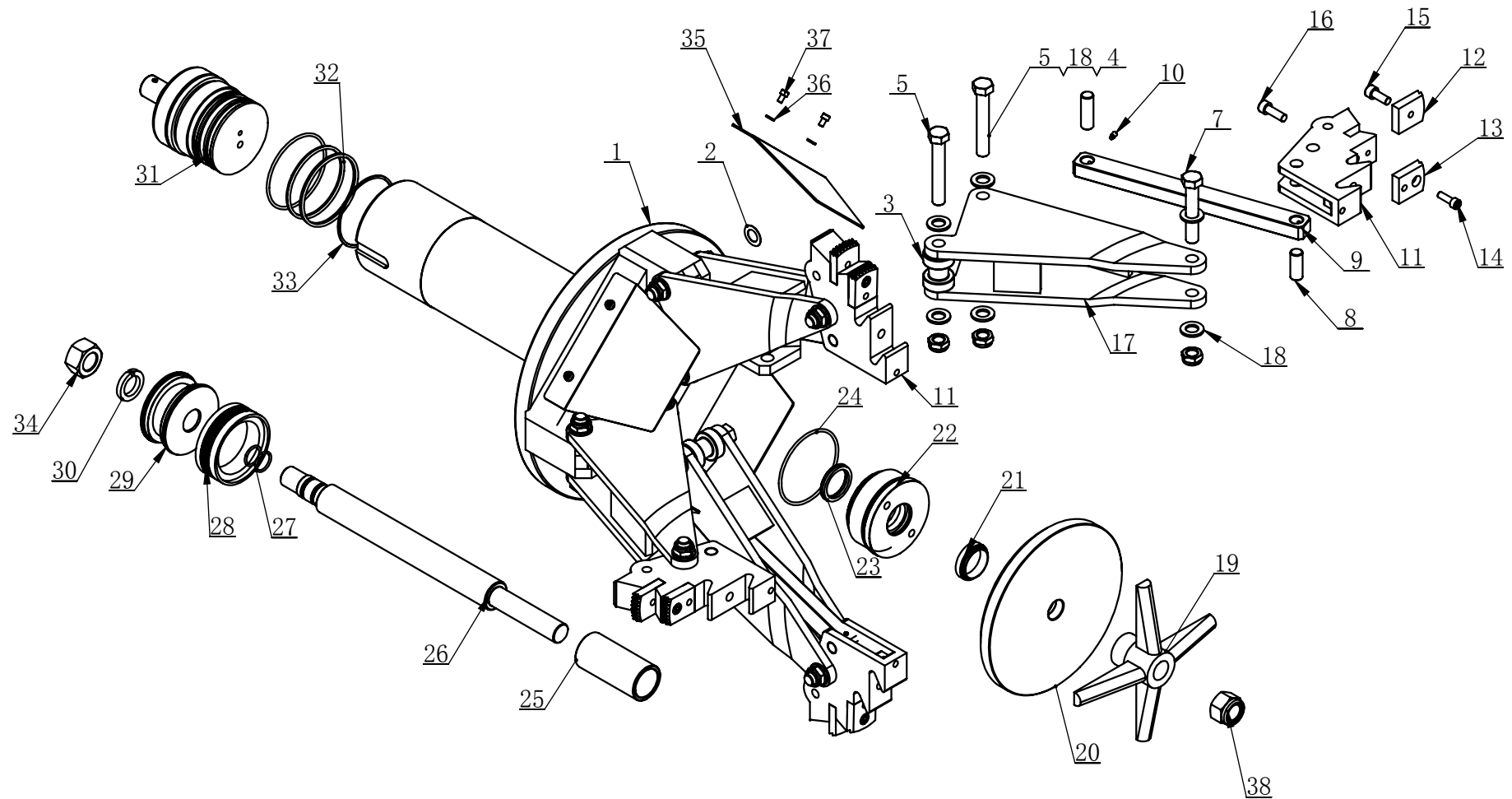

TR57.03.00.00.00

60031616 PRINCIPAL AXIS ASSEMBLY

ITEM	PART №	Description.	QTY
1	6001617	CLAMP DISK	1
2	6001622	ADJUSTING WASHER	7
3	6001623	ROLLER	4
4	5000105	NUT M16	12
5	5010136	BOLT M16X100	8
6	6001624	PIN SHAFT	1
7	5000084	BOLT M16X90	4
8	6001625	PIN SHAFT	4
9	6001626	CONNECTION PLATE	4
10	5000085	SCREW M6X12	8
11	6001627	CLAMP	4
12	6001628	CLAMP	4
13	6001629	CLAMP	4
14	5010088	SCREW M8X25	4
15	5010064	SCREW M10X25	4
16	5000033	SCREW M10X30	4
17	6001630	CLAMP SUPPORT	4
18	5010073	WASHER 16	24
19	6001635	BRACKET	1
20	6001638	PAD BOARD	1
21	5500077	防尘圈DHS40X48X5	1
22	6001639	CYLINDER HEAD COVER	1
23	5500078	密封圈UNP40X50X10	1
24	5500079	O-RINGS A 100X3.55	2
25	6001640	SPACER	1
26	6001641	PISTON ROD	1
27	5500080	O-RING A 23.6X2.65	2
28	5500081	组合圈TW100X75X22.4	1
29	6001642	PISTON	1
30	5000058	WASHER 27	1
31	6001643	OIL TANK HEAD COVER	1
32	5500063	O-RING A 95X3.55	2
33	6001644	BLOCK RING	3
34	5000087	NUT M27X2	1
35	6001591	PROTECTIVE PLATE	4
36	5000007	WASHER 6	9
37	5004220	SCREW M6X10-N	8
38	5004237	LOCK NUT M27*2	1

5500091 OIL GUIDE VALVE CORE ASSEMBLY

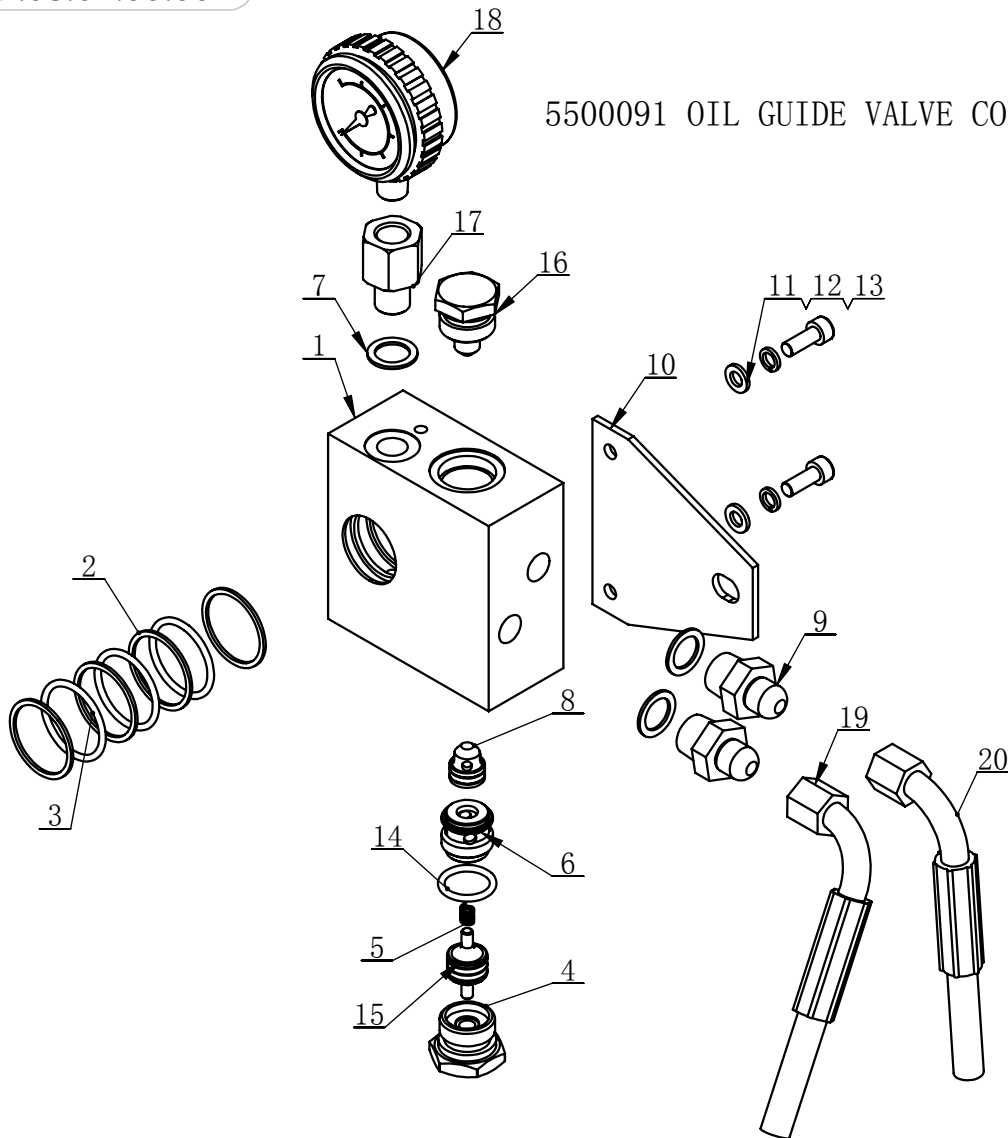

ITEM	PART №	Description.	QTY
1	6001557	OIL GUIDER VALVE BODY	1
2	6001558	WASHER	4
3	5500118	RING A 30X2.65	3
4	6001559	HEXAGON VALVE COVER	1
5	5500117	SPRING	1
6	6001561	VALVE SUPPORT	1
7	6001508	WASHER	3
8	6001563	VALVE	1
9	6001738	DOUBLE SCREW	2
10	6001565	FIXTURE PLATE	1
11	5000007	WASHER 6	2
12	5010058	WASHER 6	2
13	5009015	SCREW M6X16	2
14	5500119	O-RING A 18X2.65	2
15	6001566	VALVE	1
16	6001567	WIRE PLUG	1
17	6001568	PRESSURE GAUGE CONNECTOR	1
18	5500116	PRESSURE GAUGE 35MPa	1
19	5004239	PRESSURE HOSE A L=1.4	1
20	5004238	PRESSURE HOSE A L=1.5	1

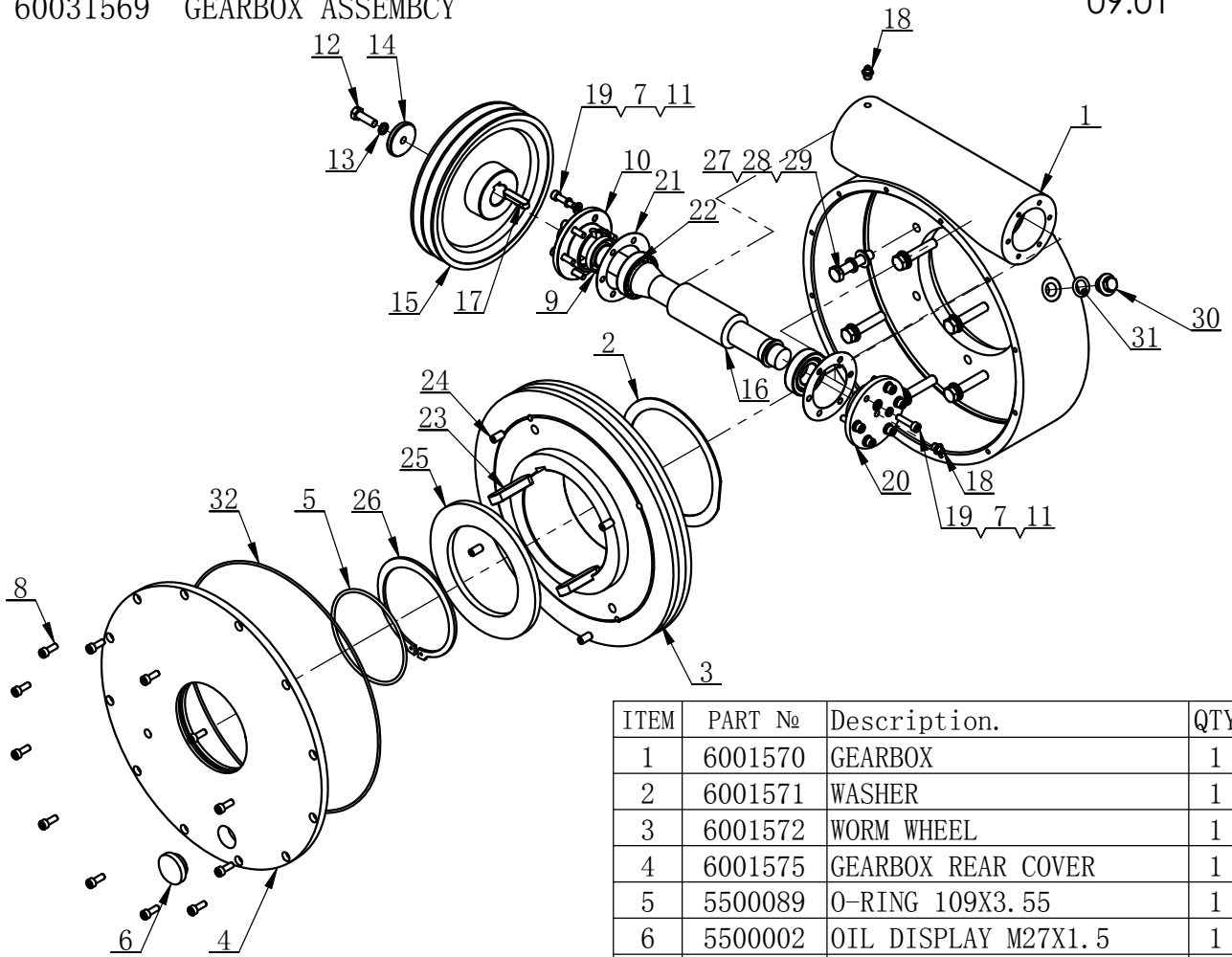

ITEM	PART №	Description.	QTY
1	6001570	GEARBOX	1
2	6001571	WASHER	1
3	6001572	WORM WHEEL	1
4	6001575	GEARBOX REAR COVER	1
5	5500089	O-RING 109X3.55	1
6	5500002	OIL DISPLAY M27X1.5	1
7	5010058	WASHER 6	12
8	5009015	SCREW M6X16	12
9	5000016	SEALING WASHER W42X25X7	1
10	6001577	GEARBOX FRONT COVER	1
11	1000109	WASHER 6	12
12	5000107	BOLT M8X25-N	1
13	5004046	WASHER 8	1
14	6001578	CIRCLIP	1
15	6001579	LARGE BELT PULLEY	1
16	6001580	WORM ROD	1
17	5000132	KEY 8X36	1
18	5000012	OIL CUP M8X1	2
19	5006006	SCREW M6X25	12
20	6001581	GEARBOX REAR COVER	1
21	6001582	PAPER WASHER	2
22	5000015	ROLLING BEARING 30205	2
23	5004233	FLAT KEY 16X60	2
24	5004234	SCREW M8X16-N	4
25	6001590	WASHER	1
26	5004235	CIRCLIP	1
27	5004221	WASHER 10	6
28	5010006	WASHER 10	6
29	5010139	BOLT M10X50	6
30	6001155	BOLT	1
31	5000011	O-RING 15X3.55	1
32	5000009	O-RING 300X2.65	1

6003208 MAIN TRAILER

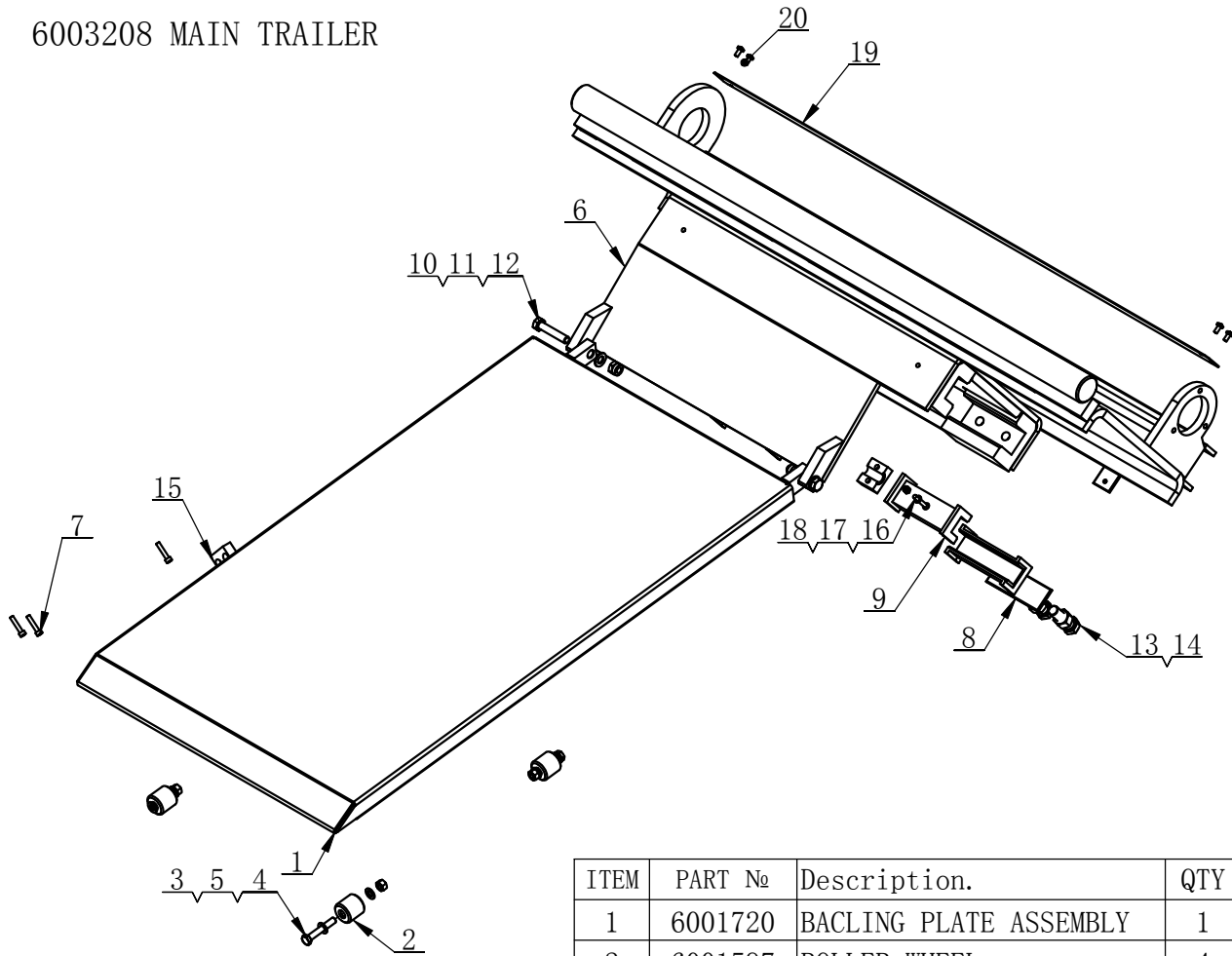

ITEM	PART №	Description.	QTY
1	6001720	BACLING PLATE ASSEMBLY	1
2	6001597	ROLLER WHEEL	4
3	5002060	NUT M8	4
4	5004241	BOLT M8X50	3
5	5000018	WASHER 8	8
6	6001742	MAIN TRAILER	1
7	5004063	SCREW M5X25	6
8	6001740	BACKING PLATE	2
9	6001741	PLASTIC GUIDE RAIL	4
10	5006001	NUT M10	2
11	5004221	WASHER 10	4
12	5000115	BOLT M10x50	2
13	5000101	BOLT M14X50	4
14	5000086	NUT M14	4
15	6001599	CABLE CLIPPING BOX	4
16	5004251	SCREW M5X35	2
17	5010045	WASHER 5	2
18	5004247	NUT M5	2
19	6003216	BAFFLE	1
20	5006439	SCREW M5X10	4

6001503 LIFTING OIL TANK

09.01

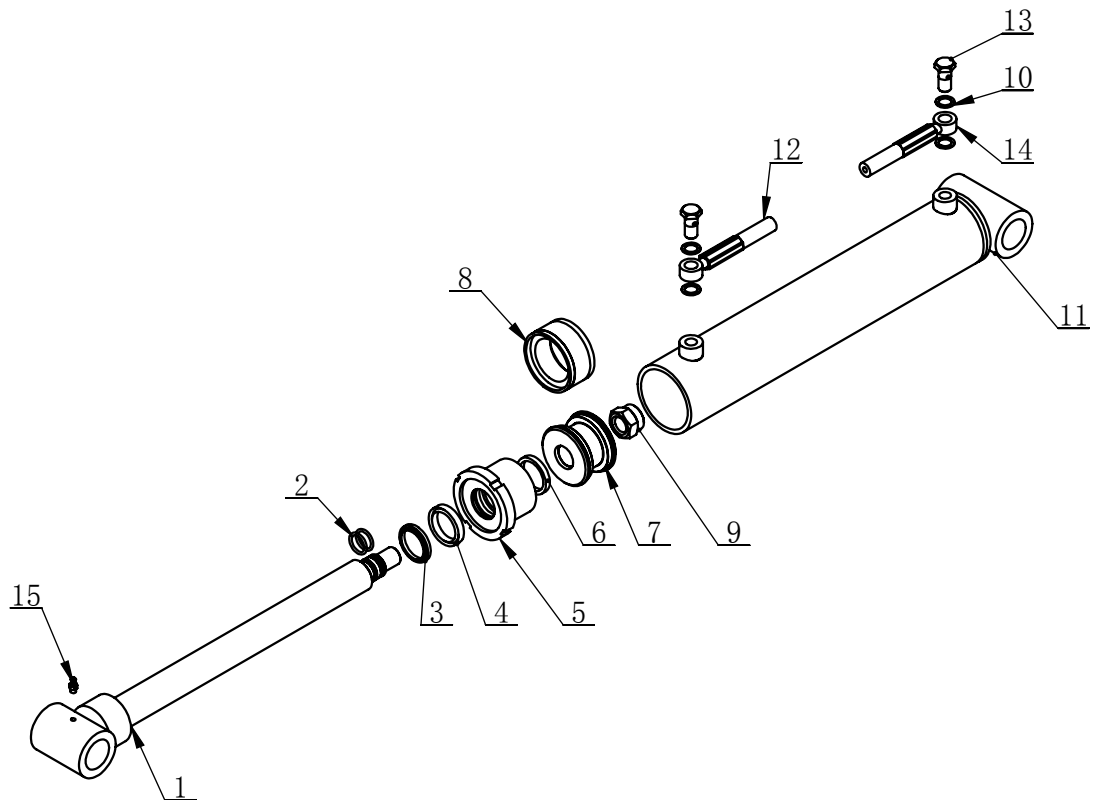

ITEM	PART No	Description.	QTY
1	6001504	PISTON ROD	1
2	5000076	O-RING 20X2.65	2
3	5500099	DUSTPROOF WASHER 41X35X4	1
4	5500100	SEALED RING 45X35X8	1
5	6001507	OIL TANK HEAD COVER	1
6	5500101	GUIDER SPACER T4X6XD35	1
7	5500102	PISTON	1
8	5500103	SEALED RING 70X50X22.4	1
9	5000109	NUT M20	1
10	6001508	WASHER	4
11	6001509	OIL TANK BODY	1
12	5500125	PRESSURE HOSE (B-TERMINATION) L=1300	1
13	6001514	CONNECTOR	2
14	5500030	PRESURE HOSE (B-TERMINATION) L=1200	1
15	5004059	OIL CUP M6	1

6001279 BRACKET OIL TANK

09.01

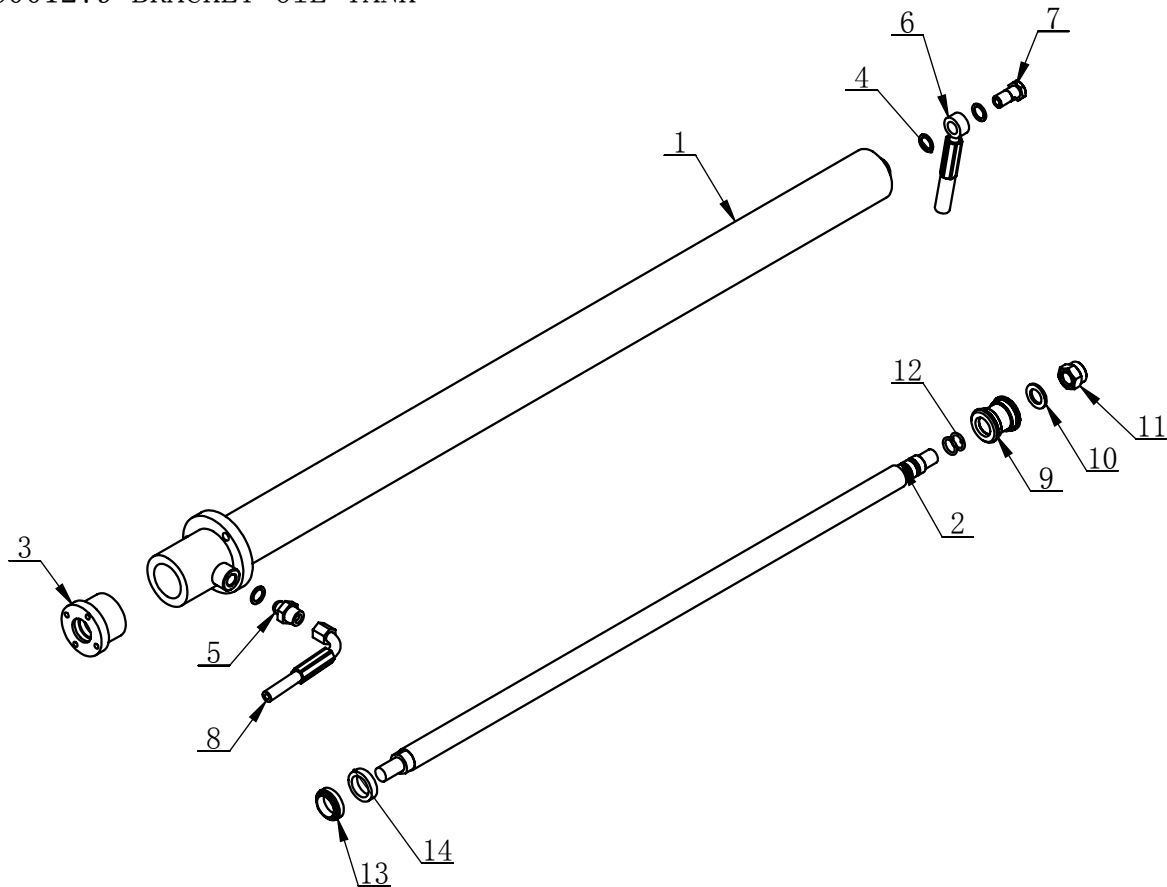

ITEM	PART №	Description.	QTY
1	6001730	OIL TANK BODY	1
2	6001735	PISTON ROD	1
3	6001736	OIL TANK HEAD COVER	1
4	6001508	WASHER	3
5	6001738	DOUBLE SCREW	1
6	5500124	PRESSURE HOSE (B-TERMINATION) L=4000	1
7	6001514	CONNECTOR	1
8	5500104	PRESSURE HOSE A L=2500	1
9	5500102	PISTON	1
10	5000110	WASHER 16-N	1
11	5004215	NUT M16	1
12	5500105	O-RING 15X2.65- A	2
13	5500106	DUSTPROOF WASHER 25	1
14	5500107	SEALED RING 25X35X8	1

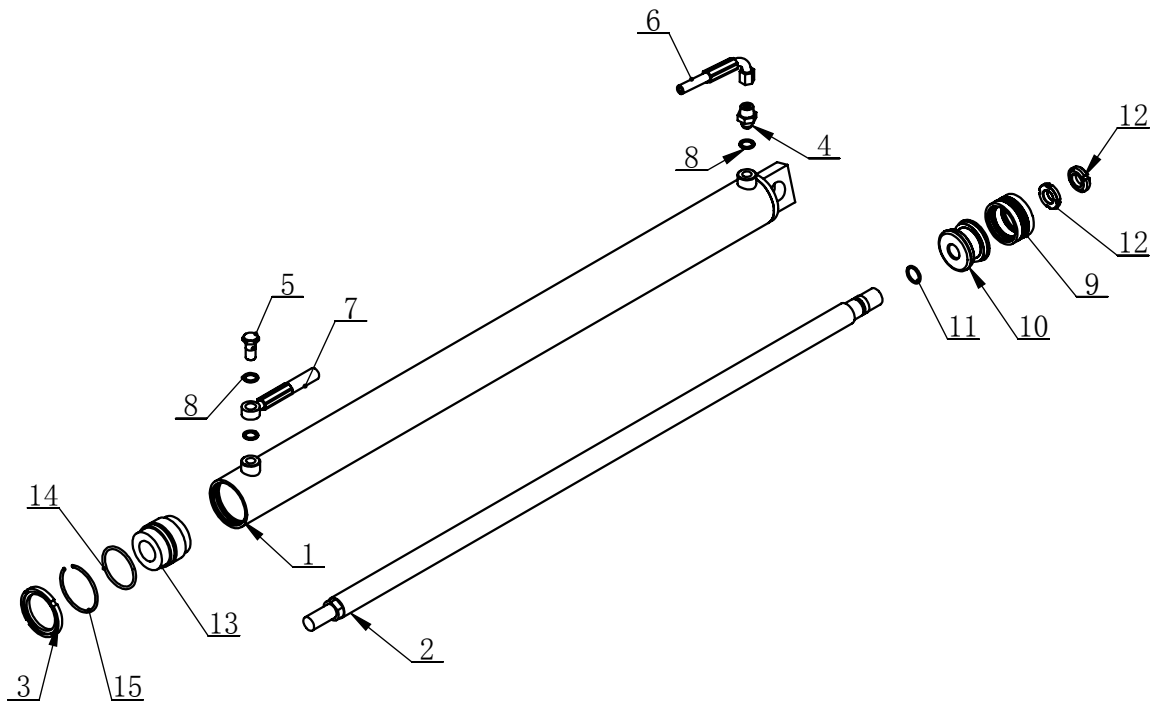

ITEM	PART No	Description.	QTY
1	6001800	CYLINDER BODY	1
2	6001805	PISTON ROD	1
3	6001831	NUT	1
4	6001738	DOUBLE SCREW	1
5	6001514	CONNECTOR	1
6	5500109	PRESSURE RUBBER HOSE A-TERMINATIO L=2000	1
7	5500030	PRESURE HOSE (B-TERMINATION) L=2300	1
8	6001508	WASHER	3
9	5500108	PISTON SEALING 60	1
10	6001829	PISTON	1
11	5000076	O-RING 20X2.65-A	1
12	5000111	NUT M20X1.5	2
13	6001830	OIL TANK HEAD COVER	1
14	5500111	O-RING A 54.5X3.55	1
15	5500110	CIRCLIP 65	1

6001666 SUPPORT ARM

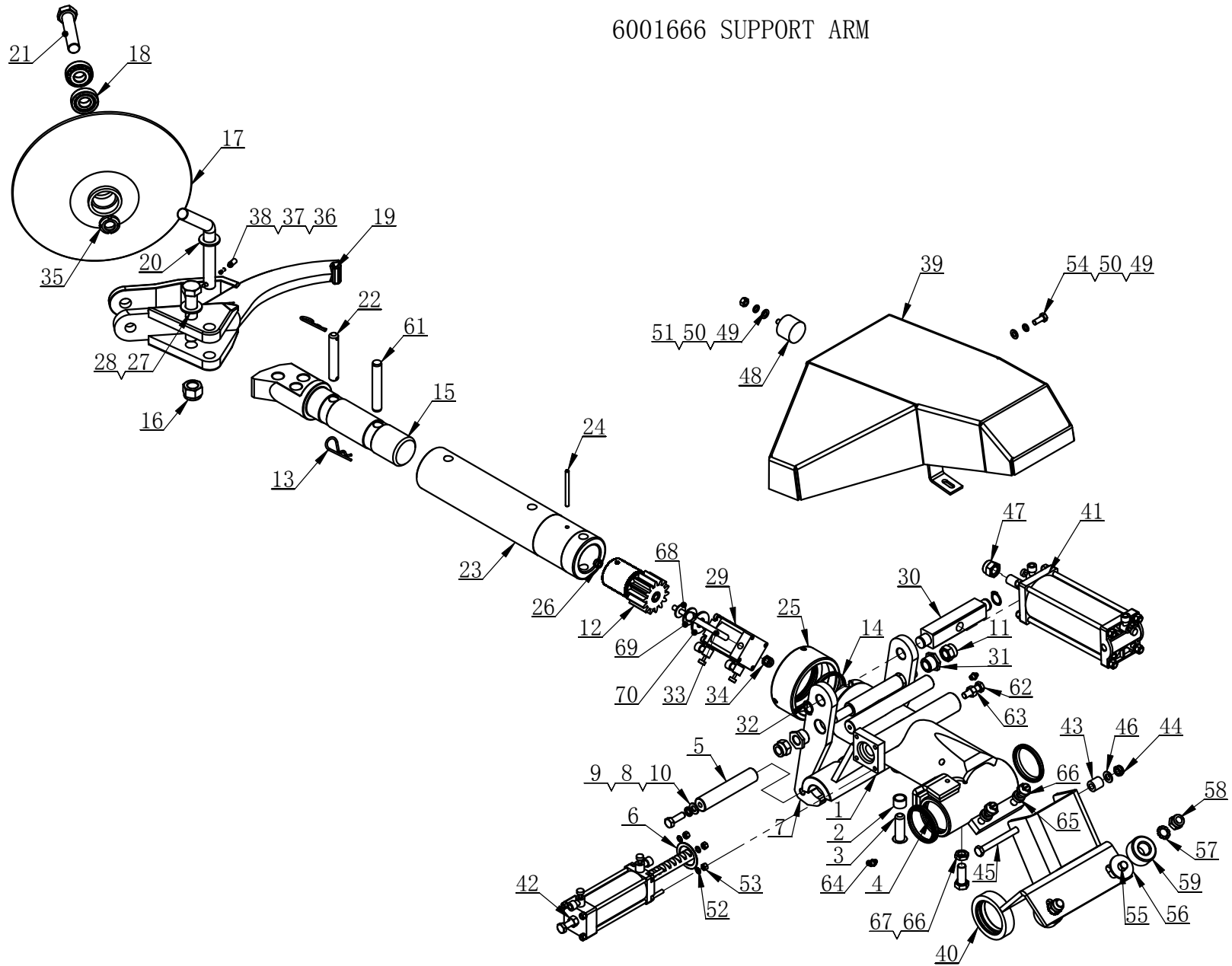

TR57.06.00.00.00

6001666 SUPPORT ARM

ITEM	PART №	Description.	QTY	ITEM	PART №	Description.	QTY
1	6001667	SUPPORT ARM	1	45	5000094	BOLT M10X130	1
2	6001681	PRESS SPRING	1	46	5004221	WASHER 10	2
3	6001682	RETAINING SHAFT	1	47	5004215	NUT M16	1
4	5500082	DUSTPROOF WASHER 58X67X6	2	48	6001600	RUBBER ROLLER	1
5	6001683	FIXTURE SHAFT	1	49	5000018	WASHER 8	3
6	6001684	CUSHION	1	50	5004046	WASHER 8	3
7	6001685	HOOK	2	51	5002060	NUT M8	1
8	5010006	WASHER 10	2	52	5000114	WASHER 6	4
9	5000103	BOLT M10X30	2	53	5004008	NUT M6	4
10	5004041	WASHER 10	2	54	5000095	BOLT M8X1.5X20	2
11	5010236	NUT M16X1.5	2	55	5006430	BOLT M14X50	2
12	6001686	GEAR	1	56	5006431	WASHER 14	2
13	5500083	CIRCLIP	2	57	5006432	WASHER 14	2
14	5500084	DUSTPROOF WASHER 80X88X8	1	58	5006433	NUT M14	2
15	6001691	SUPPORTING SHAFT	1	59	6001601	ROTATION BUSHING	2
16	5000026	NUT M20X1.5	1	60	5006434	SCREW M6X10	1
17	6001692	BEAD BREAKING DISK	1	61	5006435	PIN 16X100	1
18	5010094	TAPERED ROLLER BEARINGS	2	62	5006436	BOLT M10X35	1
19	6001695	LONG FLAT TOOL	1	63	5006120	NUT M10	1
20	6001696	HANDLE	1	64	5000012	OIL CUP M8X1	3
21	5010237	BOLT M20X1.5X95	1	65	6003026	SCREW	2
22	6001699	PIN SHAFT	1	66	5006437	NUT M14	3
23	6001700	ROTATION BUSHING	1	67	5006438	BOLT M14X35	1
24	5000120	PIN 6X75	1	68	5000090	WASHER 24X8X2	1
25	6001701	NUT-LOCK	1	69	5000130	WASHER 32X8X2	1
26	5010092	NUT M8	1	70	6001708	RUBBER BOARD	1
27	5000100	WASHER 20	1				
28	5010238	BOLT M20X1.5X100	1				
29	6001702	VERTICAL MOVABLE	1				
30	6001710	SQUARE SHAFT-QUADRA	1				
31	6001711	ACCENTRIC BUSHING	2				
32	5002032	CRICLIP 20	2				
33	5000102	BOLT M10X120	1				
34	5006001	NUT M10	1				
35	5000111	NUT M20X1.5	1				
36	5500133	STEEL BALL	1				
37	5506417	SPRING	1				
38	6003025	SCREW	1				
39	6001653	COVER	1				
40	6001659	ROTATION BRACKET	1				
41	6001645	LIFTING CYLINDER	1				
42	6001712	SUPPORT PLATE	1				
43	6001665	CUSHION BUSHING	1				
44	5010043	NUT M10	1				

6001645 LIFTING CYLINDER

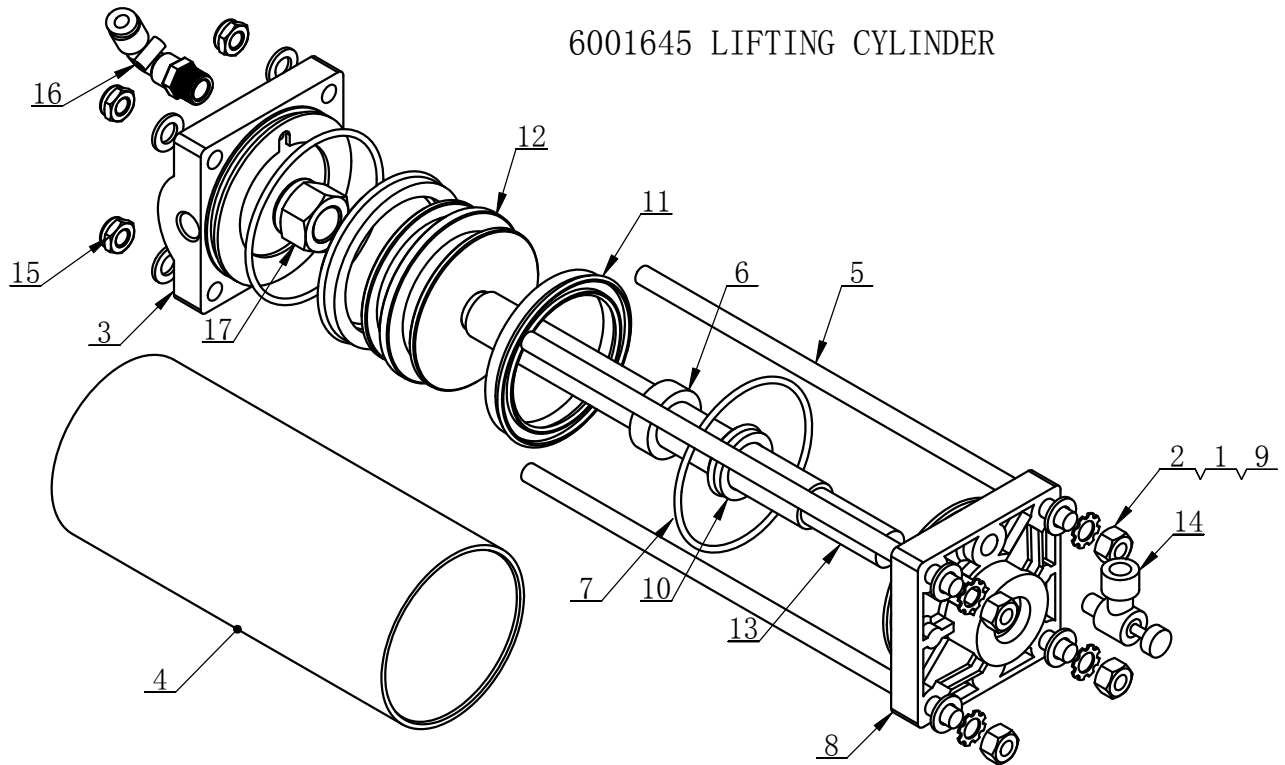

ITEM	PART №	Description.	QTY
1	5500065	WASHER 8	4
2	5002060	NUT M8	4
3	6003209	REAR COVER	1
4	6001647	CYLINDER BODY	1
5	6001648	BOLT	4
6	5500121	GUIDER SPACER 5X10X78	1
7	5500066	RING 71X2.65	2
8	6001650	FRONT COVER	1
9	5000018	WASHER 8	8
10	5500122	SOL ENOID VALVE	1
11	5500123	SEAL-ROD 75X58X9.3	2
12	6001651	PISTON	1
13	6001652	PISTON ROD	1
14	5500086	ELBOW 1/8	1
15	5010003	NUT M8	4
16	5502028	INSERT ELBOW R1/8 " Φ 6	1
17	5006450	NUT M16	1

6001702 VERTICAL MOVABLE

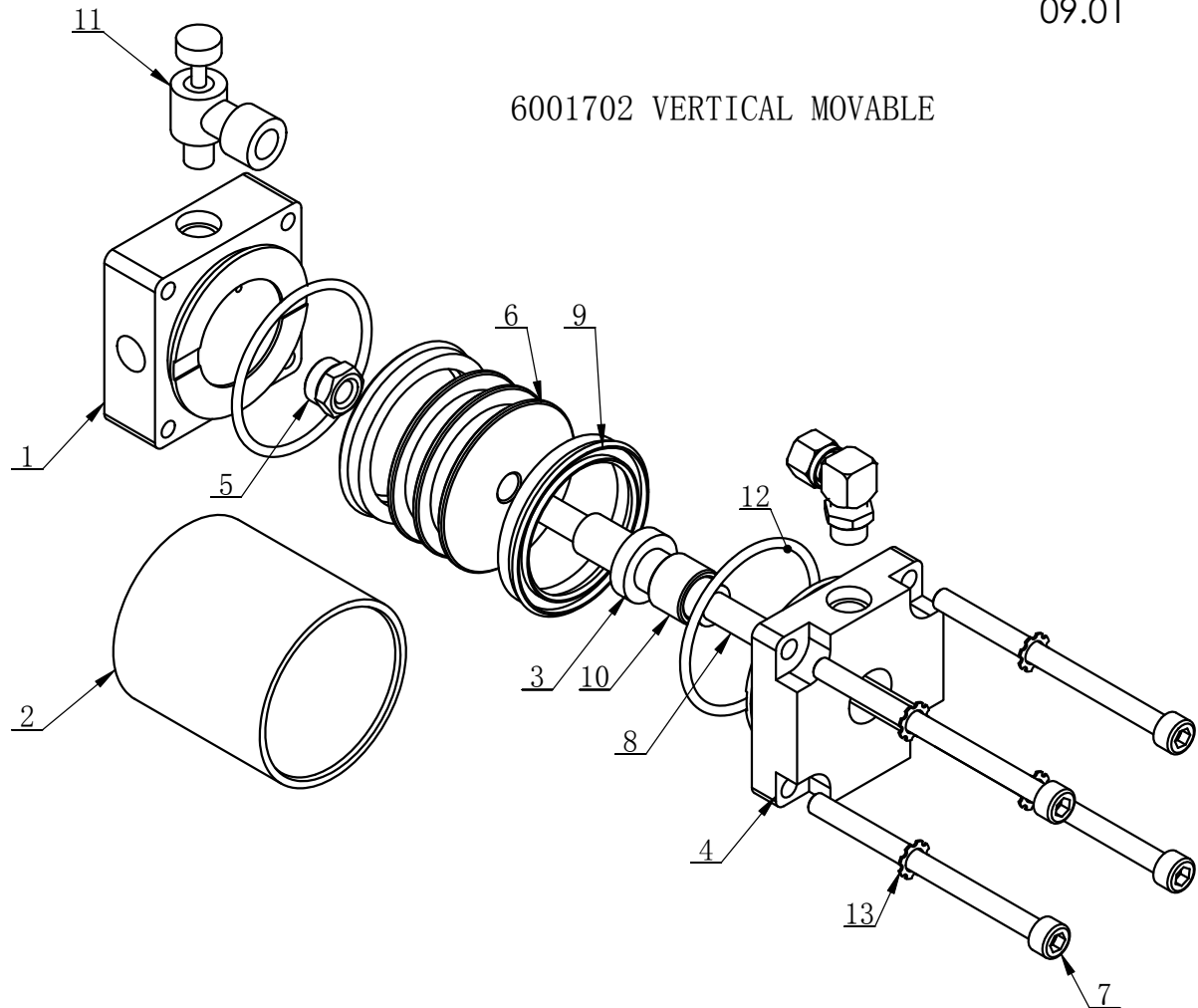

ITEM	PART №	Description.	QTY
1	6001703	REAR COVER	1
2	6001704	SLEEVE-CYLNDR	1
3	5500085	EVDIM12_20	1
4	6001705	FRONT COVER	1
5	5010092	NUT M8	1
6	6001706	PISTON	1
7	5000088	SCREW M6X85	4
8	6001707	SHAFT-CLYNDR	1
9	5500087	SEAL-ROD, CYLNDR 50X40X7.3	2
10	6001709	WEAR-RESISTANCE BUSHINH	1
11	5500086	ELBOW 1/8	1
12	5500088	RING 46.2X2.65	2
13	5006449	WASHER 6	4
14	5506511	ELBOW $\Phi 6$ 1/8	1

6001712 SUPPORT PLATE

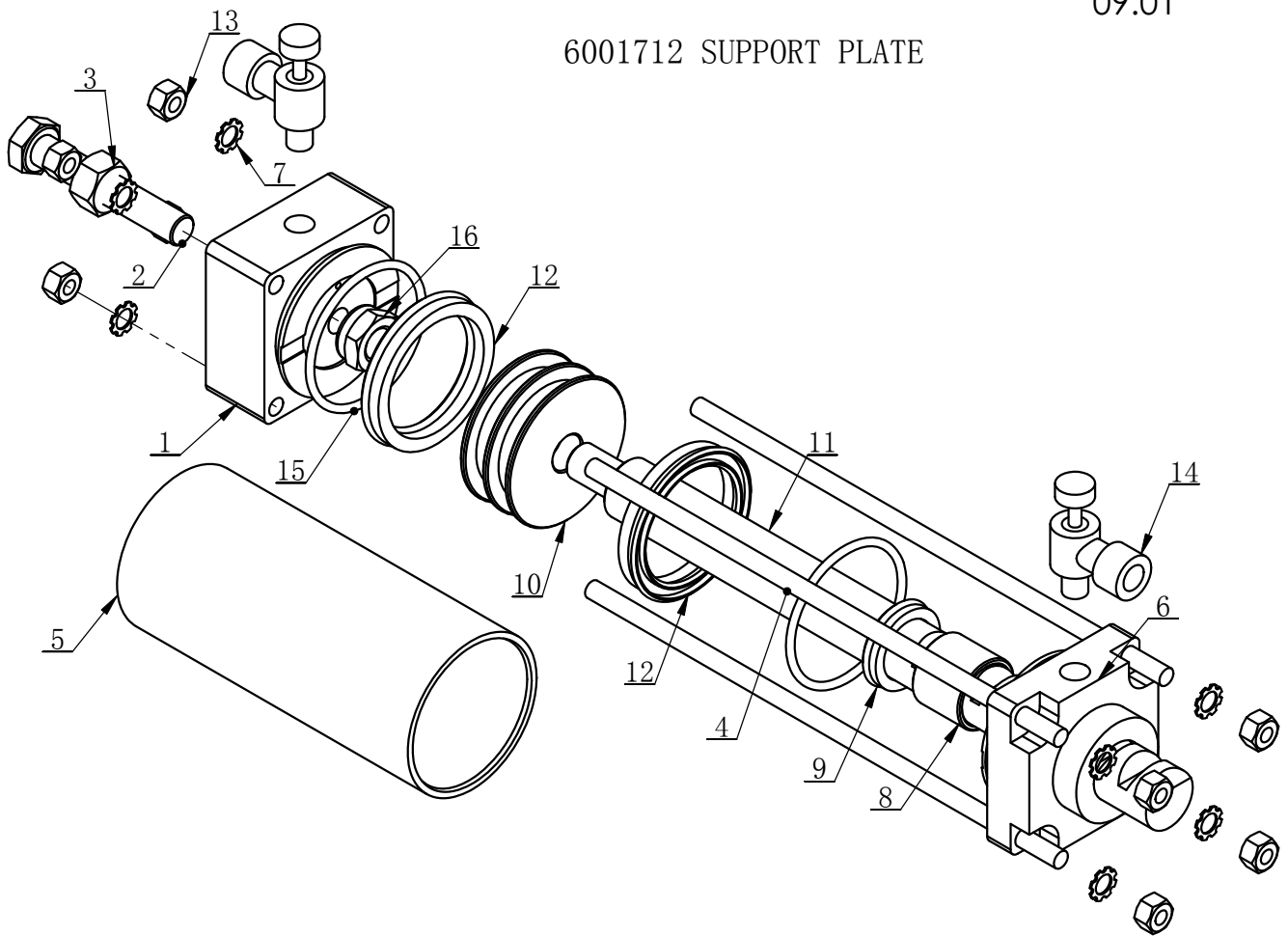

ITEM	PART №	Description.	QTY
1	5506523	REAR COVER	1
2	5006440	BOLT M10X1.5X60	1
3	5010004	NUT M10	1
4	6003215	BOLT	4
5	6003214	SLEEVE-CYLNDR	1
6	6003213	FRONT COVER	1
7	5000114	WASHER 6	8
8	6003212	WEAR-RESISTANCE BUSHINH	1
9	5506522	SEAL-ROD, CYLNDR 20X28X5.5	1
10	6003211	PISTON	1
11	6003210	PISTON ROD	1
12	5500087	SEAL-ROD, CYLNDR 50X40X7.3	2
13	5004008	NUT M6	8
14	5500086	ELBOW 1/8	2
15	5506521	RING 45X2.65	2
16	5010022	NUT M12	1

6001761 OPERATION DESK

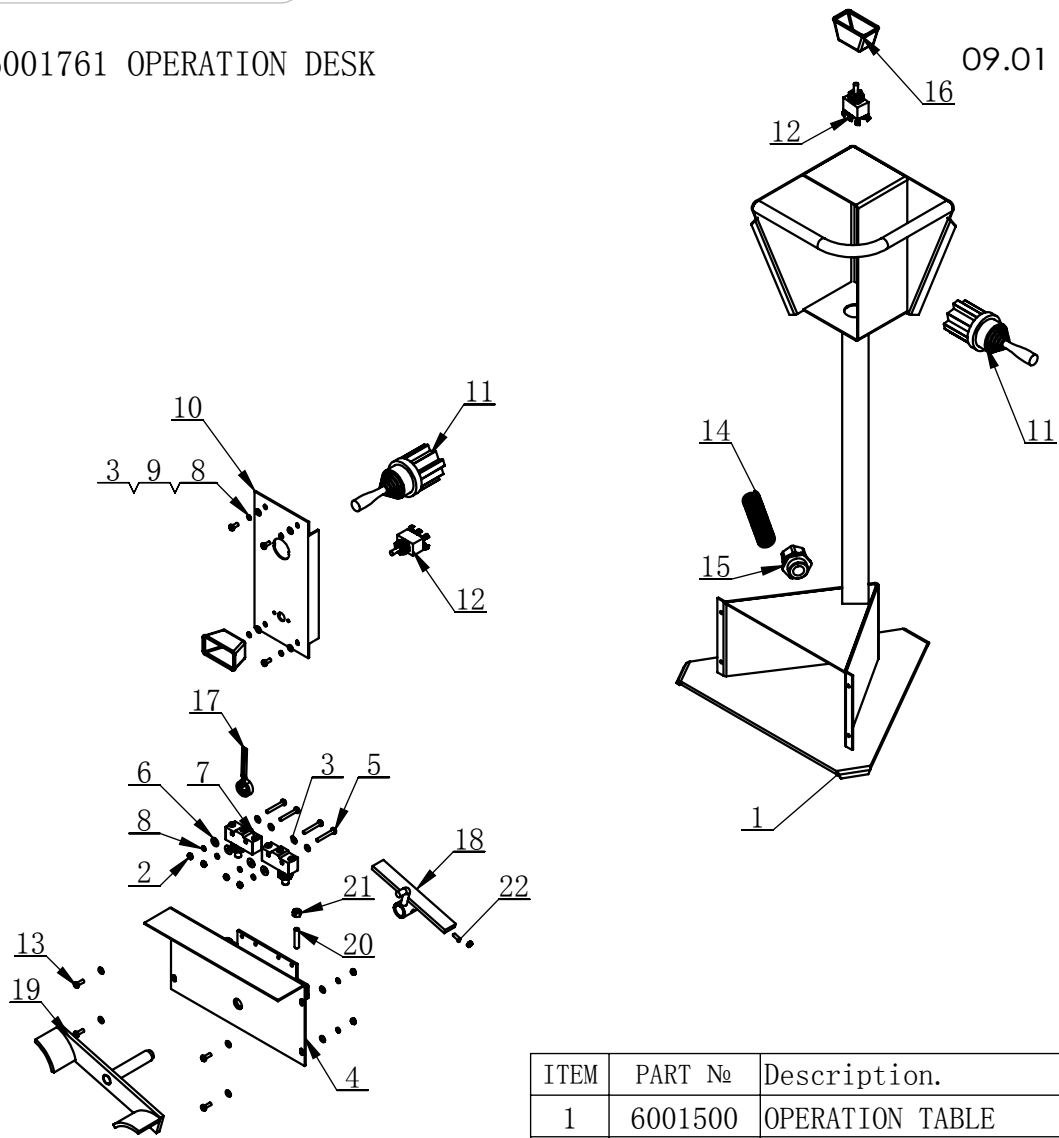

ITEM	PART No	Description.	QTY
1	6001500	OPERATION TABLE	1
2	5000063	NUT M4	9
3	5010040	WASHER 4	16
4	6001501	BRACKET	1
5	5000031	SCREW M4X30	4
6	5004049	WASHER 4	4
7	5500005	MICROSWITCHE	2
8	5000068	WASHER 4	12
9	5000010	SCREW M4X10	4
10	6001790	COVER	1
11	5500003	CROSS 30	2
12	5000083	TOGGLE SWITCH	2
13	5008007	SCREW M4X12	4
14	5500076	SPRING	1
15	5500062	CABLE LOCK M28X1.5	1
16	5500063	PROTECTIVE COVER	2
17	5500100	TORSION SPRING	1
18	6001784	SWITCH BUSHING	1
19	6001160	SHIFT DIRECTION SHAFT	1
20	5004242	SCREW M6X30	2
21	5004008	NUT M6	2
22	5004243	SCREW M4X12	1

6001815 AIR CONTROLLING ASSEMBLY

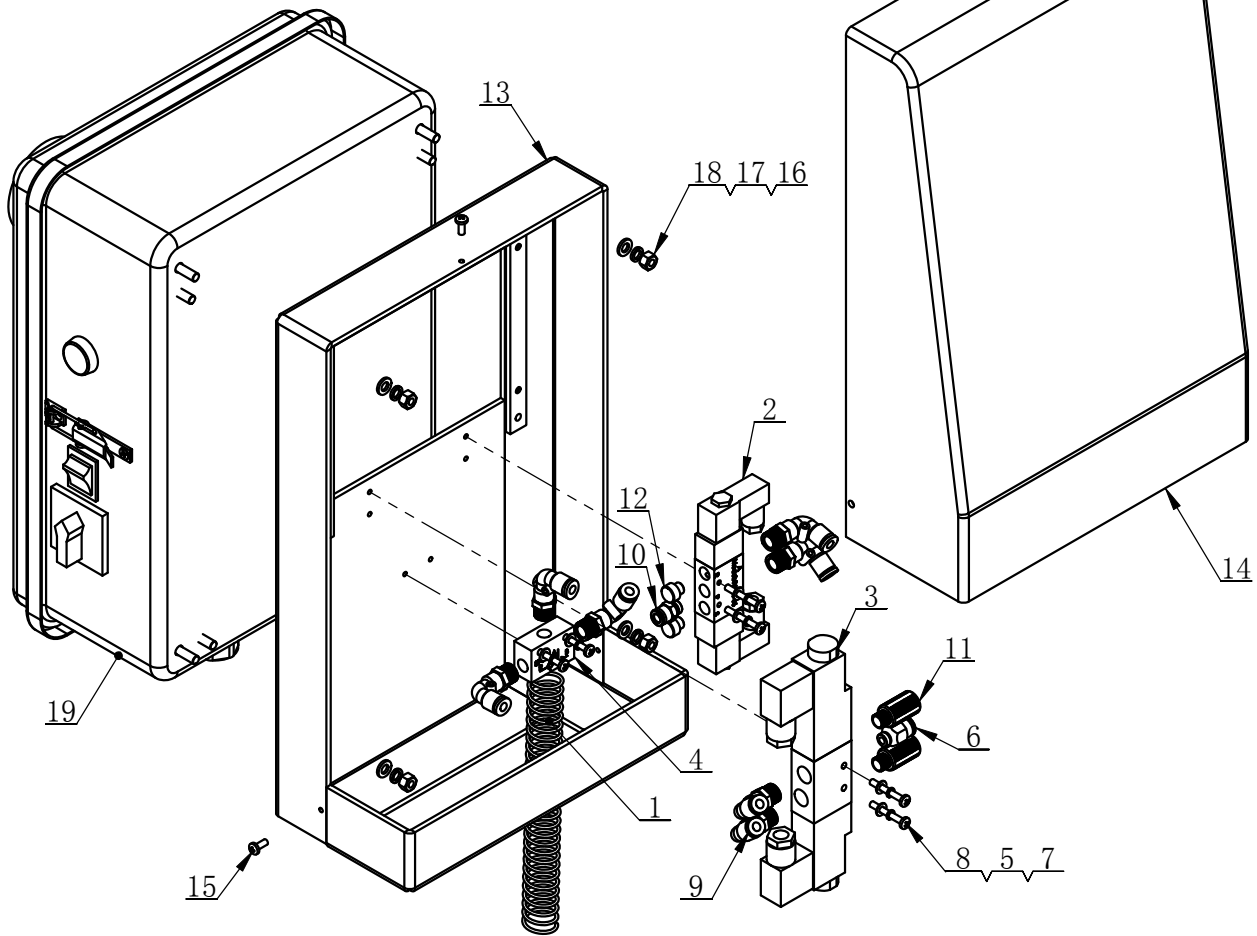

ITEM	PART No	Description.	QTY
1	6001817	SPRING	1
2	5500112	SOLENOID VALVE 4V120-06 0.15~0.8MPa	1
3	5500113	SOLENOID VALVE 4V230C-08 0.15~0.8MPa	1
4	5500114	VALVE ST-01	1
5	5000068	WASHER 4	6
6	5500115	INSERT FITTING R1/4"	1
7	5010040	WASHER 4	6
8	5000031	SCREW M4X30	6
9	5502028	INSERT ELBOW R1/8" Φ 6	7
10	5010060	INSERT FITTING Φ 6, R1/8"	1
11	5502027	SILENCER	2
12	5502007	SILENCER R1-8	2
13	5506517	FIXTURE BRACKET	1
14	5506516	PROTECTIVE COVER	1
15	5508030	SCREW M4X10	3
16	5008063	WASHER 6	4
17	5008122	WASHER 6	4
18	5504008	NUT M8	4
19	6001812	ELECTRIC CABINET ASSEMBLY	1

6001812 ELECTRIC CABINET ASSEMBLY

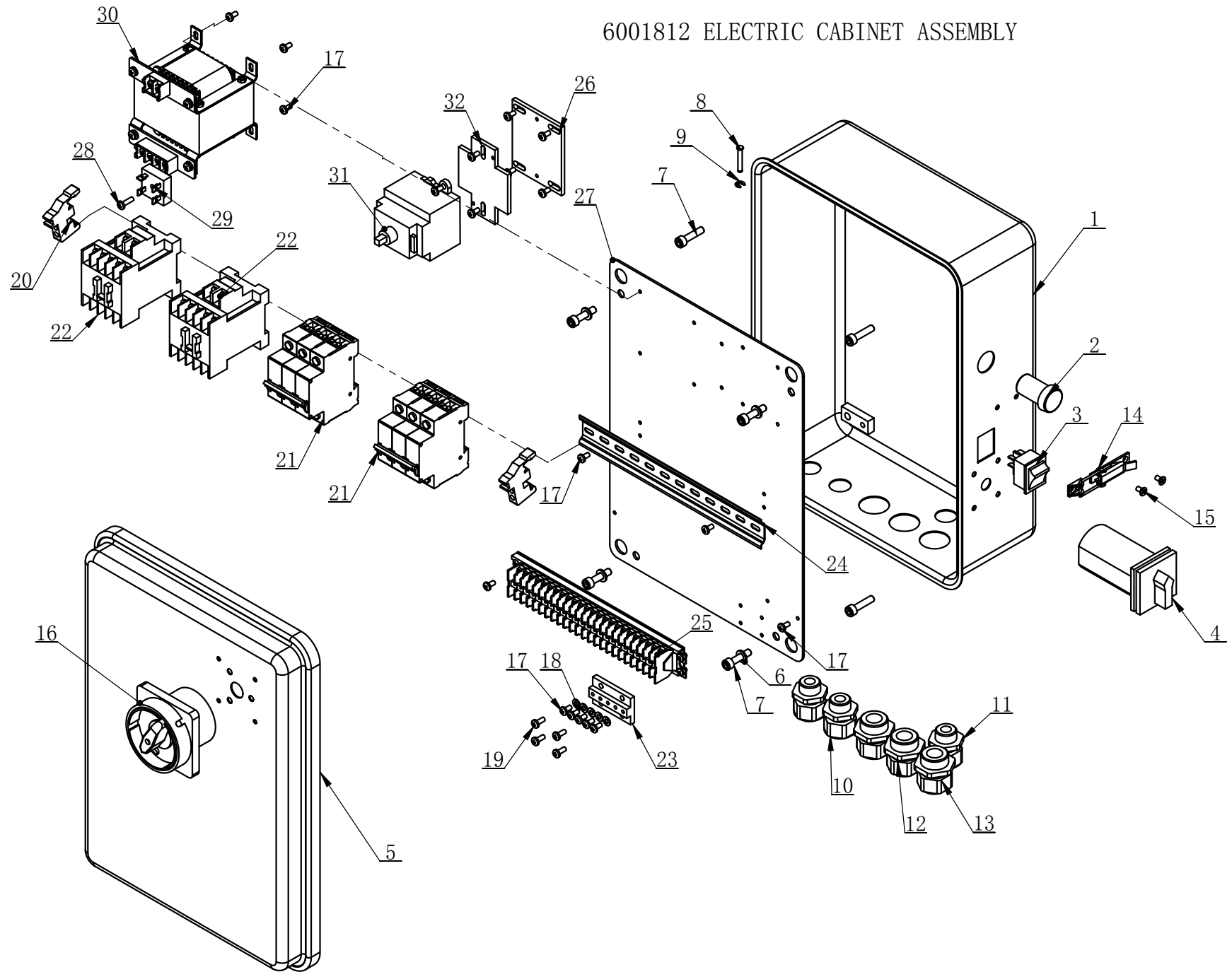

6001812 ELECTRIC CABINET ASSEMBLY

ITEM	PART №	Description.	QTY
1	5901100	ELECTRICAL CONTROL CABINET	1
2	5500056	INDICATING LIGHT AD16-22D	1
3	5506414	POWER SWITCH	1
4	5500097	TWO SPEED MOTOR PART ASSEMBLY	1
5	5901200	ELECTRICAL CABINET WELDING	1
6	5008063	WASHER 6	4
7	5006428	SCREW M6X25	8
8	5901006	LONG PIN	2
9	5002068	RING 4	2
10	5500058	CABLE LOCK M18X1.5	2
11	5502089	CABLE LOCK HEAD M20X1.5	1
12	5500062	CABLE LOCK M27X1.5 PG21	2
13	5500062	CABLE LOCK M28X1.5	1
14	5506415	DOOR LOCK	1
15	5509097	SCREW M4X8	2
16	5500055	COMBINED SWITCH ASSEMBLY	1
17	5009007	SCREW M4X8-8	21
18	5008069	WASHER 4	5
19	5000010	SCREW M4X10	4
20	5500053	FIXTURE CLAMP	2
21	5500052	TRI-POLE CIRCUIT BREAKER	2
22	5500051	AC CONTACTOR S-P12	2
23	6001081	GROUND TERMINATOR	1
24	5500046	LONG FIXED PLATE 35mm	1
25	5500127	LINE BANK ASSEMBLY	1
26	6001836	BOARD	1
27	6001833	ELECTRICAL BLOCK BOARD	1
28	5000098	SCREW M4X14	1
29	5500049	RECTIFIER BRIDGE BLOCK KBPC-2510	1
30	5500042	TRANSFORMER ASSEMBLY JBK3-100	1
31	5500126	COMBINED SWITCH ASSEMBLY	1
32	6001837	SWITCH FIX UPPER PLATE	1

ACCESSORY

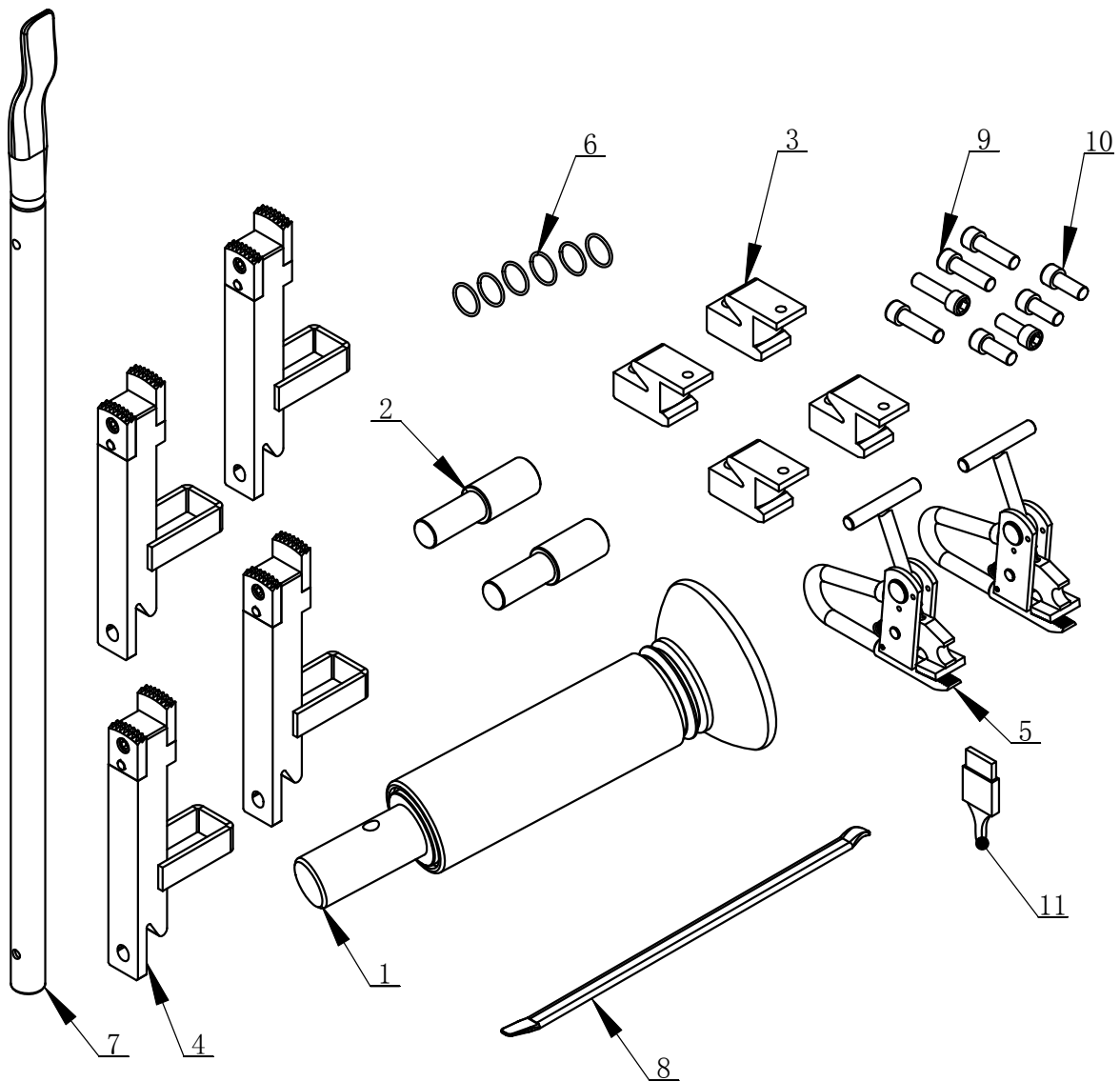

ITEM	PART №	Description.	QTY
1	5506520	PRESS ROLLER (OPTIONAL)	1
2	6001770	PIN (OPTIONAL)	2
3	6001698	NYLON PROTECTIVE JAW (OPTIONAL)	4
4	6003206	EXTENSION JAW (OPTIONAL)	4
5	6001157	CALIPER	2
6	5006442	RING 30X2.65	6
7	5506519	CROWBAR	1
8	5500038	24INCH CROWBAR	1
9	5006443	SCREW M14X50 (OPTIONAL)	4
10	5006444	SCREW M14X35 (OPTIONAL)	4
11	5506518	BRUSH	1