

ГРУЗОВОЙ ШИНОМОНТАЖНЫЙ СТАНОК ГШС-516К

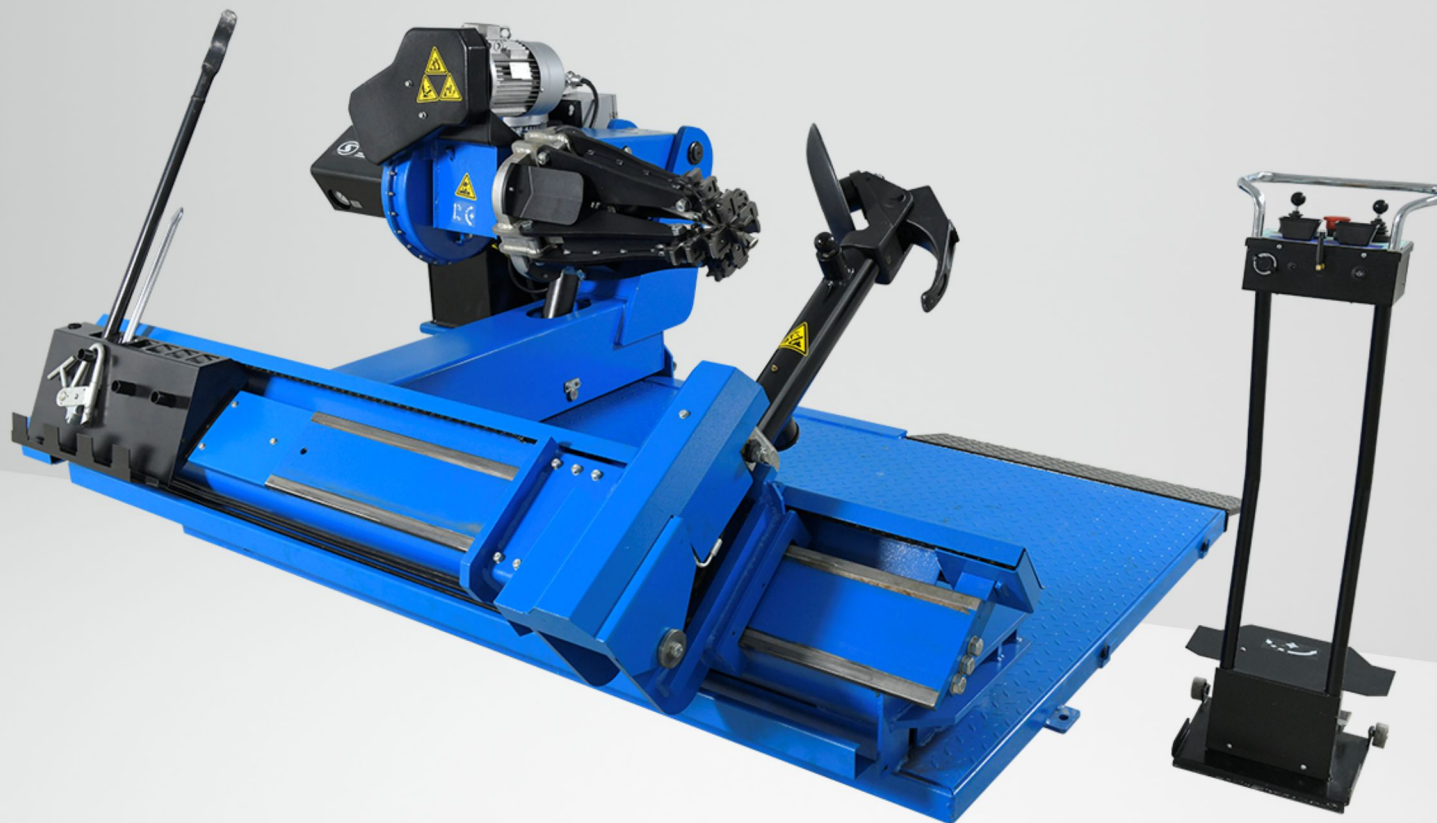

КАТАЛОГ ЗАПЧАСТЕЙ

EAC

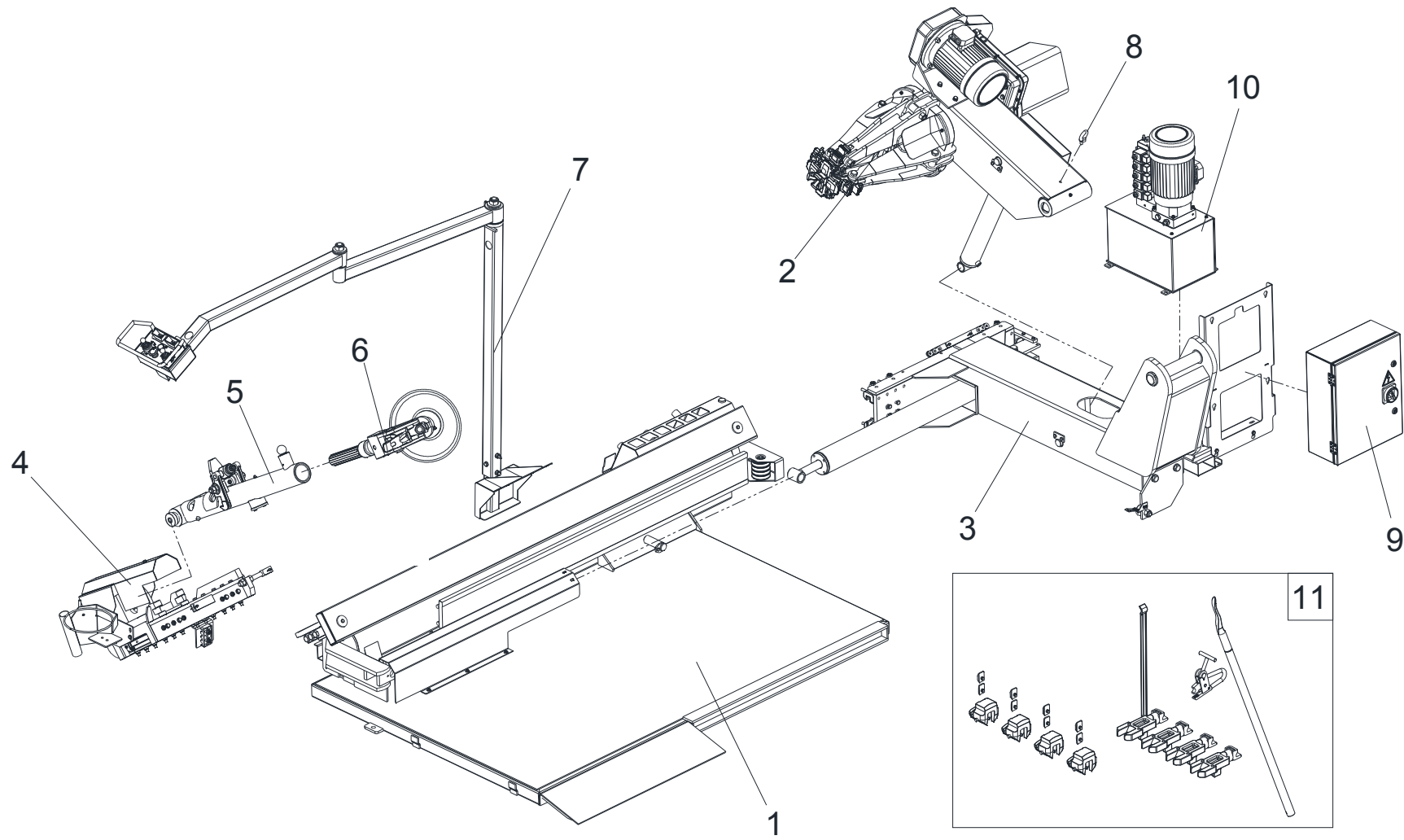

TAV.0	GENERAL ASSEMBLY	ED. 11/19
-------	------------------	-----------

ITEM	PART NO.	DESCRIPTION	QTY	REMARK
1	C56D100000	Frame	1	
2	C56D200000B	Self-centering chuck	1	
3	C56D300000	Arm support	1	
4	C56D410000	Carriage	1	
5	C56D420000	Tool holder arm	1	
6	C56D402000	Double tool	1	
7	C56D180000	Rotation control unit	1	
8	0215028	Bolt M12 - GB/T825	1	
9	C56DD11000	Electric unit	1	
10	C56DY10000	Hydraulic power unit	1	
11	C56D001000	Accessories	1	

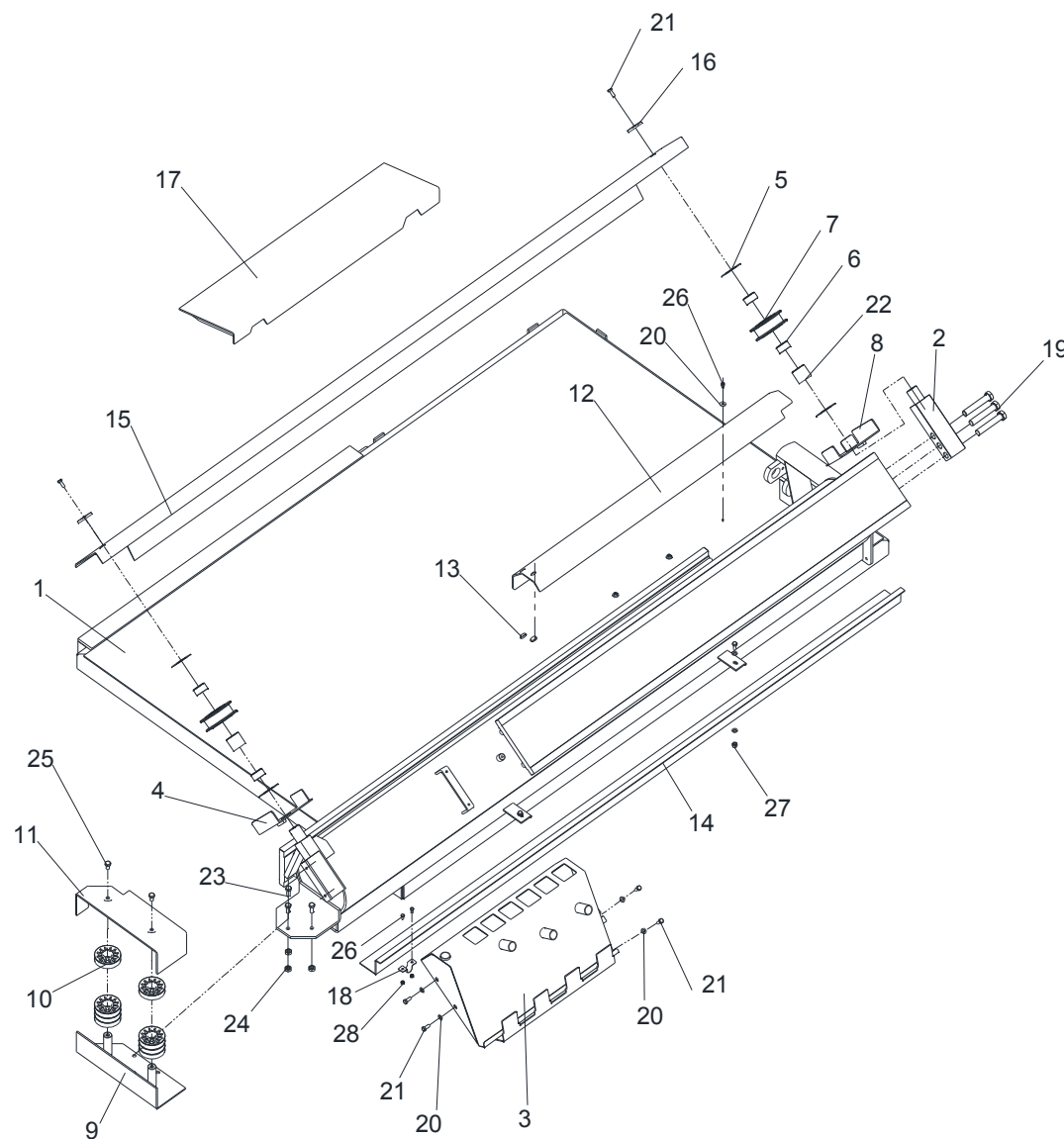

TAV.1.0	FRAME	ED. 11/19
---------	-------	-----------

ITEM	PART NO.	DESCRIPTION	QTY	REMARK
1	C56D101000	Base	1	
2	C56D100001	Pulley shaft	1	
3	C56D020000	Tool support	1	
4	C56D103000	Right pulley cover	1	
5	C56D100004	Washer	4	
6	C56D100005	Bush	4	
7	C56D100006	Pulley	2	
8	C56D104000	Left pulley cover	1	
9	C56D040000	Support	1	
10	C56D000005	Roller	8	
11	C56D000002	Roller cover	1	
12	C56D000003	Cylinder cover	1	
13	C56D000004	Nylon washer	2	
14	C56D000001	Back cover	1	
15	C56D030000	Front cover	1	
16	C56D000006	Washer	2	
17	C56D102000	Ramp	1	
18	C56D000011	Cable clamp	1	
19	0201105	Screw M18X1.5X100 - GB/T5785	3	
20	0205007	Washer D.6 - GB/T96	12	
21	0201042	Screw M8X20 - GB/T5783	9	
22	0210031	Self-lubricated bush 4040	2	
23	0201064	Screw M10X25 - GB/T5783	3	
24	0204005	Self-locking nut M10	3	
25	0201059	Screw M10X16 - GB/T5783	2	
26	0201010	Screw M6X12 - GB/T5781	5	
27	0204004	Nut M8 - GB/T889.1	2	

TAV.1.0	FRAME	ED. 11/19
---------	-------	-----------

28

0204003

Nut M6 - GB/T889.1

2

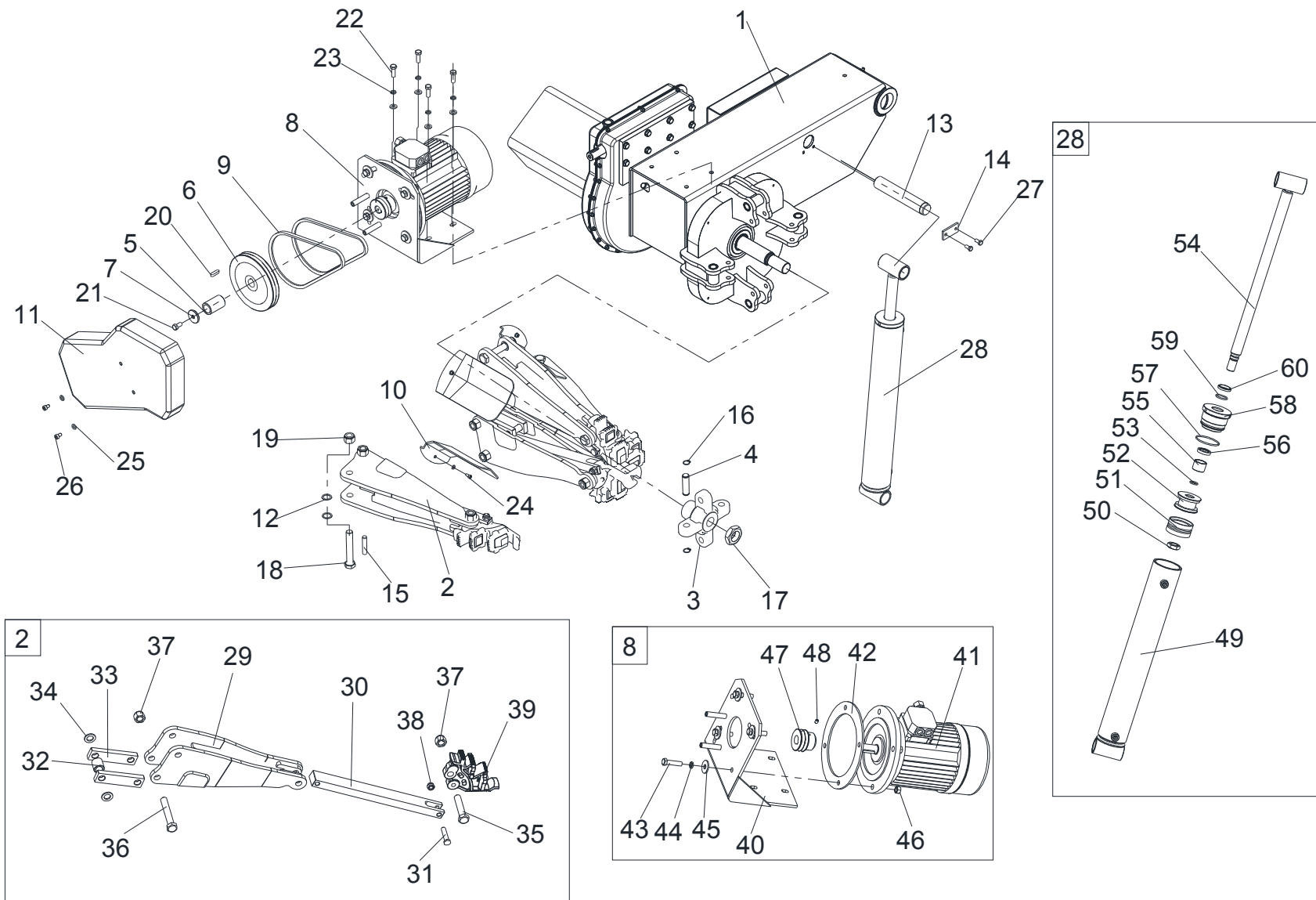

ITEM	PART NO.	DESCRIPTION	QTY	REMARK
1	C56D200000A	Chuck	1	
2	C56B230000	Clamp unit	4	
3	YC8-3001050a	Turntable cross	1	
4	YC8-3000993	Pin	4	
5	YC8-3000999a	Spacer	1	
6	YC8-3001052b	Driven pulley	1	
7	YC8-3001068	Washer	1	
8	C56D240000	Motor unit	1	
9	0606077	Belt	2	
10	C56B200002	ABS cover	4	
11	C56B250001	Belt casing	1	
12	YC8-4399974	Copper washer	8	
13	C56D200004	Cylinder shaft	1	
14	C60A200012	Plate	1	
15	0213039	Elastic pin 12X60	4	
16	0212016	Seeger D.18 - GB/T894.1	8	
17	0204019	Nut M33X2.0 - GB/T6173	1	
18	0201146	Screw M18X1.5X110 - GB/T5785	4	
19	0204010	Nut M18X1.5 - GB/T6184	4	
20	0213025	Tab 8X30 - GB/T1096	1	
21	0201062	Screw M10X20 - GB/T5783	1	
22	0201049	Screw M10X30 - GB/T5783	4	
23	0208007	Washer D.10 - GB/T93	8	
24	0202024	Screw M6X12 - GB/T70.1	4	
25	0205008	Washer D.8 - GB/T97.1	6	
26	0202043	Screw M8X12 - GB/T70.1	2	
27	0201026	Screw M8X16 - GB/T5783	2	

TAV.2.0	SELF-CENTERING CHUCK	ED. 11/19
---------	----------------------	-----------

28	C56BY20000	Chuck arm cylinder	1
29	C56B231000	Arm	1
30	C56B230002	Bar	1
31	YC8-3000968	Special screw	1
32	YC8-3000994	Spacer	1
33	YC8-3001044a	Connection rod	2
34	0205021	Washer D.18	2
35	0201107	Screw M18X85X1.5	1
36	0201146	Screw M18X1.5X110 - GB/T5785	1
37	0204010	Self-locking nut M18X1.5	2
38	0204007	Self-locking nut M12	1
39	YC8-2003200	Clamp	1
40	C56D241000	Support	1
41	0509123	Double speed motor 400V/3PH/50HZ 2.6KW/3.2KW	1
42	C56B240001	Spacer	1
43	0201157	Screw M12X50	4
44	0208009	Spring washer D.12	4
45	0205014	Washer D.12	4
46	0203023	Nut M12	4
47	YC8-3000975	Motor pulley	1
48	0209046	Screw M8X10 - GB/T80	1
49	C56BY22000	Cylinder liner	1
50	0204048	Screw M22X1.5	1
51	0312014	Gasket 70X50 X22.4	1
52	YA-70-3	Piston	1
53	0309022	O-ring 24X2.4	1
54	C56BY24000	Cylinder shaft	1

TAV.2.0	SELF-CENTERING CHUCK	ED. 11/19
---------	----------------------	-----------

55	0305006	Guiding ring 30X25X2.5	1
56	0310009	Sealing ring 30X38X7	1
57	0309050	O-ring 70X3.1	1
58	C56BY28005	Cylinder guiding cover	1
59	0309027	O-ring 35X3.1	1
60	0311005	Scraper 30X38X5/6.5	1

TAV.2.1	CHUCK	ED. 11/19
---------	-------	-----------

ITEM	PART NO.	DESCRIPTION	QTY	REMARK
1	C56D210000	Chuck arm	1	
2	C56D200002	Spacer	1	
3	C56D200003	Self-lubricated washer	1	
4	C56D200005	Washer	1	
5	C56D200007	Self-lubricated washer	1	
6	C56D230000	Cover	1	
7	YC8-3010838A	Helical gear	1	
8	YC8-3008803	Locking plate	2	
9	YC8-3001009	Worm support	1	
10	YC8-3010861b	Worm screw	1	
11	CC-410104	Washer	1	
12	YC8-3001114	Washer	1	
13	YC8-3001010	Oil screen	1	
14	YC8-4299309	Steel ring for scraper	1	
15	0311008	Scraper 40X48X5	1	
16	YC8-3010893A	Bush for chuck rod	1	
17	YC8-3001051	Gasket	1	
18	YC8-3000998	Cover	1	
19	0305018	Oil plug 3/8	1	
20	YC8-6609764	Pivot union cover	1	
21	YC8-4199258	Oil plug	1	
22	0606064	Plug	1	
23	0309045	O-ring 95X3.1	1	
24	0309117	O-ring 95X5.7	1	
25	0213029	Tab 20X60	2	
26	0214014	Bear	2	
27	0214009	Bearing 51205	2	

TAV.2.1	CHUCK	ED. 11/19
---------	-------	-----------

28	0204014	Nut M16X1.5	2
29	0201049	Screw M10X30	3
30	0201050	Screw M10X35	6
31	0205011	Washer D.10	11
32	0202024	Screw M6X12	2
33	0205006	Washer D.6	2
34	0202032	Screw M6X16	22
35	0202034	Screw M6X25	1
36	0203035	NUT M6	25
37	0203032	Nut M10 - GB/T6170	1
38	0215024	Oil level indicator M27X1.5	1
39	0202043	Screw M8X12	4
40	0210128	Bush	2
41	0215021	Greaser 8X1	1
42	C56D200006	Seal	1
43	C56D200001	Ring for felt	1
44	C56D220000	Chuck turntable	1
45	0311032	Scraper	1
46	0309013	O-ring 115X3.55	1
47	YC8-140-0	Chuck cylinder	1
48	YC8-140-6	Cylinder shaft	1
49	0309114	O-ring 32X3.1	1
50	0312008	Gasket 140X115X25.4	1
51	YC8-140-5	Piston	1
52	0209060	Screw M8X12 - GB/T77	1
53	0203032	Nut M10 - GB/T6170	8
54	0309049	O-ring 195X5.7	1

55	YC8-140-7	Cylinder guide cover	1
56	0309046	O-ring 140X3.1	1
57	0305012	Guide ring 40X12X2.5	1
58	0310013	Sealing ring 40X50X6	1
59	YC8-140-4	Cylinder liner	1
60	0202117	Screw M10X60 - GB/T70.1	8
61	0202118	Screw M10X70 - GB/T70.1	4
62	0305001	Plug	1
63	0309025	O-ring 30X3.1	1
64	YC8-140-3	Pin	1
65	0202026	Screw M6X30	3
66	0313004	Ring 26X20X1.5	3
67	0313014	Sealing ring 20X3.53	3
68	YC8-140-2	Pivot union body	1
69	0205009	Washer D.8	1
70	0201023	Screw M8X12 - GB/T5783	1
71	0305056	Pressure gauge 250bar	1

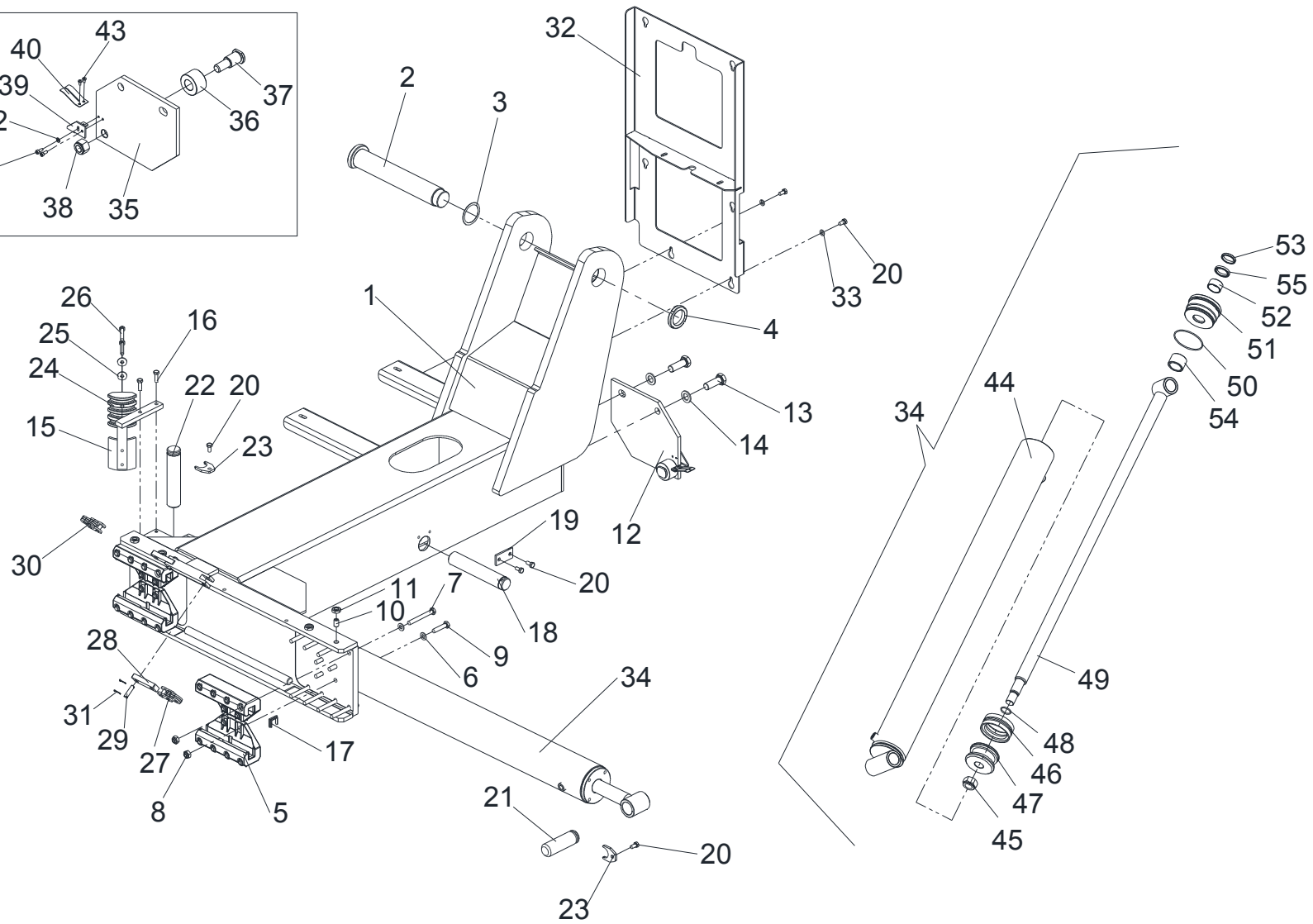
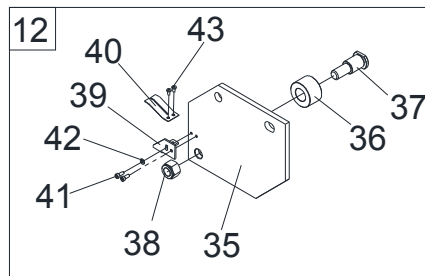

ITEM	PART NO.	DESCRIPTION	QTY	REMARK
1	C56D310000	Frame	1	
2	C56D300001	Pin	1	
3	C60A200022	Washer	2	
4	0204046	Nut M45X1.5	1	
5	C56D300002	Slider	4	
6	0205011	Washer D.10 - GB/T97.1	24	
7	0201054	Screw M10X85 - GB/T5782	15	
8	0204005	Self -locking nut M10	23	
9	0201051	Screw M10X45 - GB/T5782	8	
10	0209091	Screw M14X25 - GB/T77	4	
11	0204013	Nut M14 - GB/T6172.1	4	
12	C56D320000	Roller unit	1	
13	0201246	Screw M18X1.5X50 - GB/T5786	2	
14	0205021	Washer D.18 - GB/T97.1	2	
15	C56D331000	Support	1	
16	0201038	Screw M8X25 - GB/T5783	2	
17	C56D300009	Scraper	8	
18	C56D200004	Shaft	1	
19	C60A200012	Plate	1	
20	0201026	Screw M8X16 - GB/T5783	6	
21	C56D300006	Cylinder pin	1	
22	C56D300005	Pin	1	
23	C56D300007	Fastening plate	2	
24	C56D000007	Hose clamp	1	
25	0205009	Washer D.8	2	
26	0201020	Screw M8X55 - GB/T5782	2	
27	0215143	Chain BL844	1	

TAV.3.0	ARM SUPPORT	ED. 11/19
---------	-------------	-----------

28	C56D000008	Connection board	2
29	BL 844	Chain pin	2
30	0215142	Chain BL844	1
31	0213037	Pin	4
32	C56D051000	Support	1
33	0205008	Washer D.8 - GB/T97.1	2
34	C56DY90000	Carriage Cylinder	1
35	C56D320001	Roller support	1
36	C56D320002	Roller	1
37	C56D320003	Roller pin	1
38	0204010	Nut M18X1.5	1
39	C56D320004	Bracket	1
40	C56D320005	Forked leaf spring	1
41	0202016	Screw M5X12 - GB/T70.1	2
42	0205004	Washer D.5	1
43	0206023	Screw M4X8 - GB/T818	2
44	C56DY91000	Cylinder liner	1
45	0204039	Nut M24X2	1
46	0312018	Gasket 90X70X22.4	1
47	MN-4296462	Piston	1
48	0309114	O-ring 32X3.1	1
49	C56DY92000	Piston rod	1
50	0309076	O-ring 84.4X3.1	1
51	C56DY98001	Cylinder guiding cover	1
52	0305008	Guide ring 35X20X2.5	1
53	0311006	Scraper 36X44X5/6.5	1
54	C56DY98008	Spacer	1
55	0310010	Sealing ring 35X45X6	1

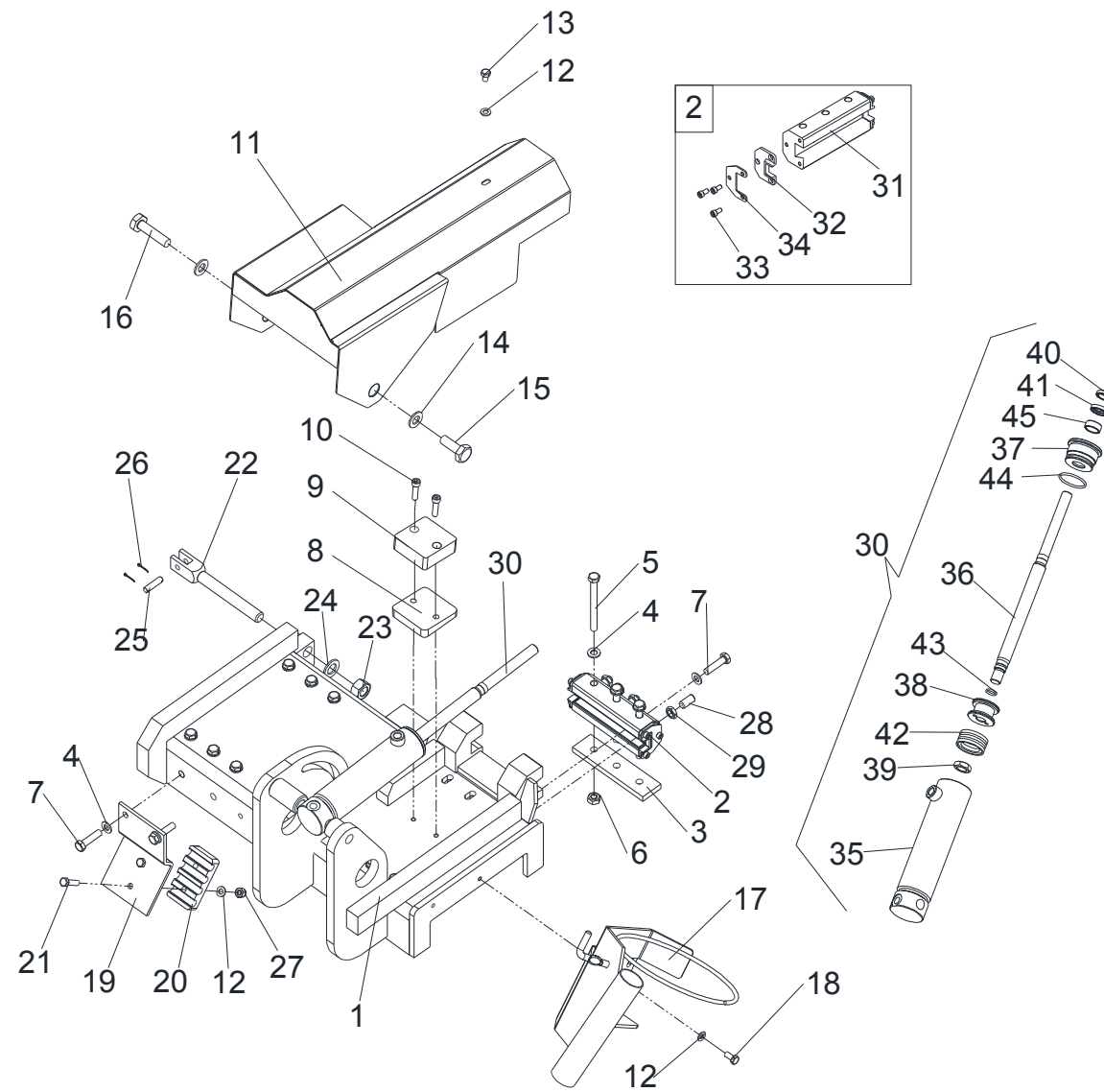

TAV.4.0	CARRIAGE	ED. 11/19
---------	----------	-----------

ITEM	PART NO.	DESCRIPTION	QTY	REMARK
1	C56D411000	Carriage	1	
2	C56D401000	Slider	4	
3	C56D400016	Plate	4	
4	0205011	Washer D.10 - GB/T97.1	20	
5	0201141	Screw M10X100 - GB/T5782	12	
6	0204005	Self -locking nut M10	12	
7	0201123	Screw M10X40 - GB/T5782	8	
8	C56D400011	Cushion plate	1	
9	C56D400012	Rubber cushion	1	
10	0202049	Screw M8X30 - GB/T70.1	2	
11	C56D451000	Protection cover	1	
12	0205008	Washer D.8 - GB/T97.1	5	
13	0201023	Screw M8X12 - GB/T5783	1	
14	0205017	Washer D.14 - GB/T97.1	2	
15	0201091	Screw M14X60 - GB/T5782	1	
16	0201091	Screw M14X60 - GB/T5782	1	
17	C60A141000	Tool support	1	
18	0201026	Screw M8X16 - GB/T5783	2	
19	C56D100003	Support	1	
20	C60A100023	Base	1	
21	0201117	Screw M8X35 - GB/T5783	2	
22	C56D000010	Shaft	1	
23	0203022	Nut M18X1.5	2	
24	0205021	Washer D.18 - GB/T97.1	1	
25	BL 844	Chain pin	2	
26	0213037	Pin	4	
27	0204004	Nut M8 - GB/T889.1	2	

TAV.4.0	CARRIAGE	ED. 11/19
---------	----------	-----------

28	0209016	Screw M12X25 - GB/T77	5
29	0204016	Nut M12	5
30	C56DY54000	Tool hooking cylinder	1
31	C56D401001	Slider	1
32	C56D401002	Scraper	2
33	0202024	Screw M6X12	6
34	C56D401004	Anti-derailment plate	2
35	C56DY54100	Cylinder liner	1
36	C56DY54804	Piston shaft	1
37	C51BY28001	Cylinder guide cover	1
38	C51BY28002	Piston	1
39	0204014	M16X1.5	1
40	0311022	Scraper 20X28X4.5/6	1
41	0310006	Sealing ring 20X28X5.7	1
42	0312004	Gasket 45X31X15.5	1
43	0309019	O-ring 18X2.4	1
44	0309060	O-ring 45X3.1	1
45	0305007	Guide ring 20X10X2.5	1

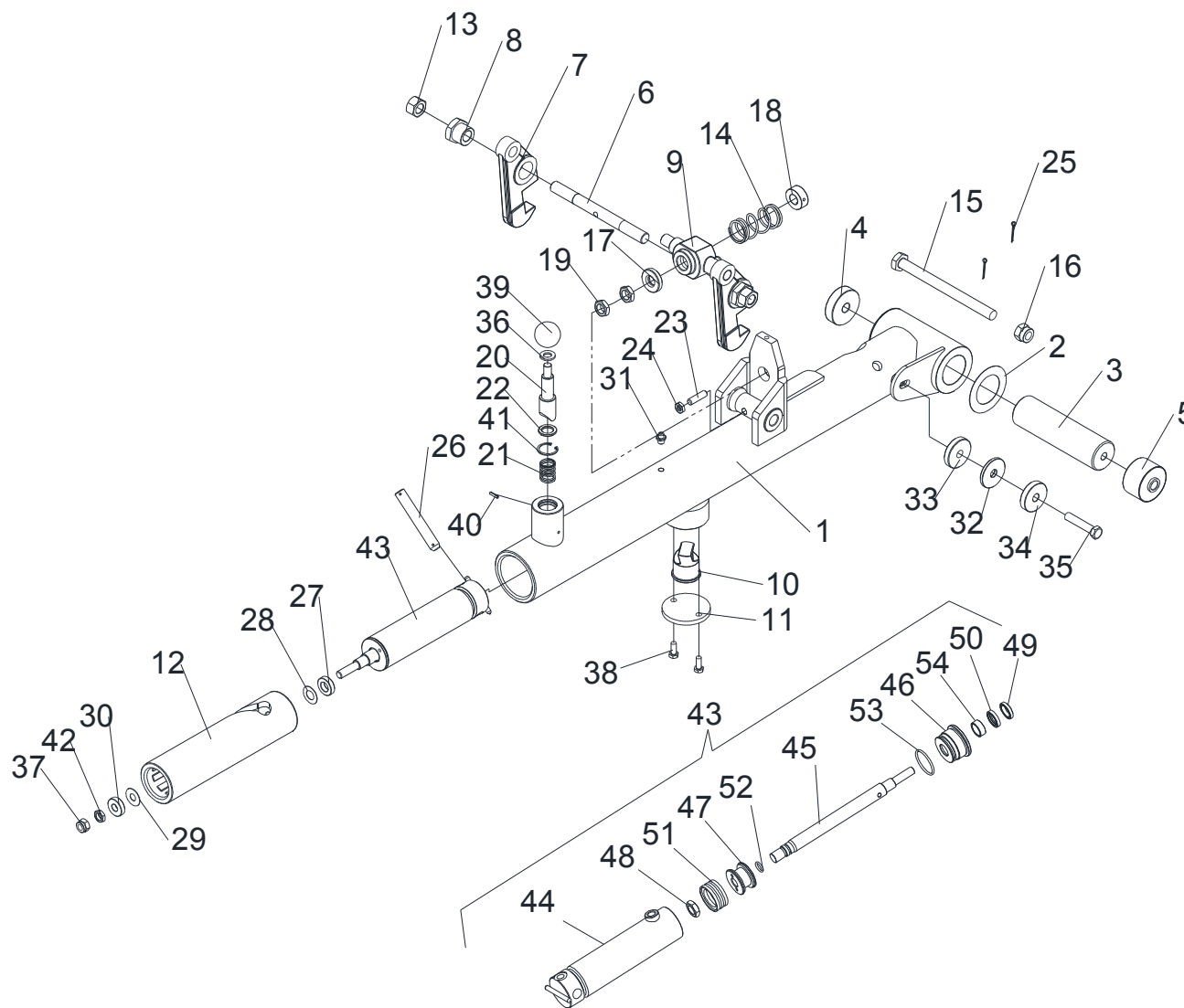

TAV.5.0	TOOL HOLDER ARM	ED. 11/19
---------	-----------------	-----------

ITEM	PART NO.	DESCRIPTION	QTY	REMARK
1	C56D421000	Post	1	
2	C56D400009	Washer	2	
3	C56D400004	Pin	1	
4	C56D400022	Spacer	1	
5	C56D400021	Spacer	1	
6	C56D400005	Connection shaft	1	
7	C56D400002	Hook	2	
8	C56D400003	Cam	2	
9	C56D400006	Support	1	
10	C56D400007	Slider	1	
11	C56D400008	Side plate	1	
12	C56D441000	Rotation hub unit	1	
13	0203022	Nut M18X1.5 - GB/T6171	2	
14	C56D400013	Spring	1	
15	0201249	Screw M16X200 - GB/T5782	1	
16	0204008	Self-locking nut M16	1	
17	C56D400014	Washer	1	
18	C56D400015	Spacer	1	
19	0204014	Nut M16X1.5 - GB/T6173	2	
20	C56D400017	Pin	1	
21	C56D400018	Spring	1	
22	C56D400019	Ring	1	
23	0209045	Screw M10X35 - GB/T77	1	
24	0204012	Nut M10 - GB/T6172	1	
25	0213038	Pin	2	
26	C56D400010	Shaft	1	
27	C56D440002	Washer	1	

TAV.5.0	TOOL HOLDER ARM	ED. 11/19
---------	-----------------	-----------

28	C56D440004	Adjust washer	1
29	C56D440003	Adjust washer	1
30	C56D440001	Washer	1
31	0215020	Oil Cup	1
32	C56B32006	Nylon washer	1
33	C56B32007	Nylon washer	1
34	C56B32005	Washer	1
35	0201081	Screw M12X60 - GB/T5782	1
36	0205013	Washer D.12 - GB/T97.1	2
37	0204007	Nut M12 - GB/T889.1	2
38	0201042	Screw M8X20 - GB/T5783	2
39	0215053	Ball	1
40	0213066	Elastic pin 4X16	1
41	0211004	Seeger D.30 - GB/T893.1	1
42	0204016	Nut M12	1
43	C56DY45000	Rotation cylinder	1
44	C56DY45100	Cylinder liner	1
45	C56DY45804	Piston shaft	1
46	C51BY28001	Cylinder guide cover	1
47	C51BY28002	Piston	1
48	0204014	M16X1.5	1
49	0311022	Scraper 20X28X4.5/6	1
50	0310006	Sealing ring 20X28X5.7	1
51	0312004	Gasket 45X31X15.5	1
52	0309019	O-ring 18X2.4	1
53	0309060	O-ring 45X3.1	1
54	0305007	Guide ring 20X10X2.5	1

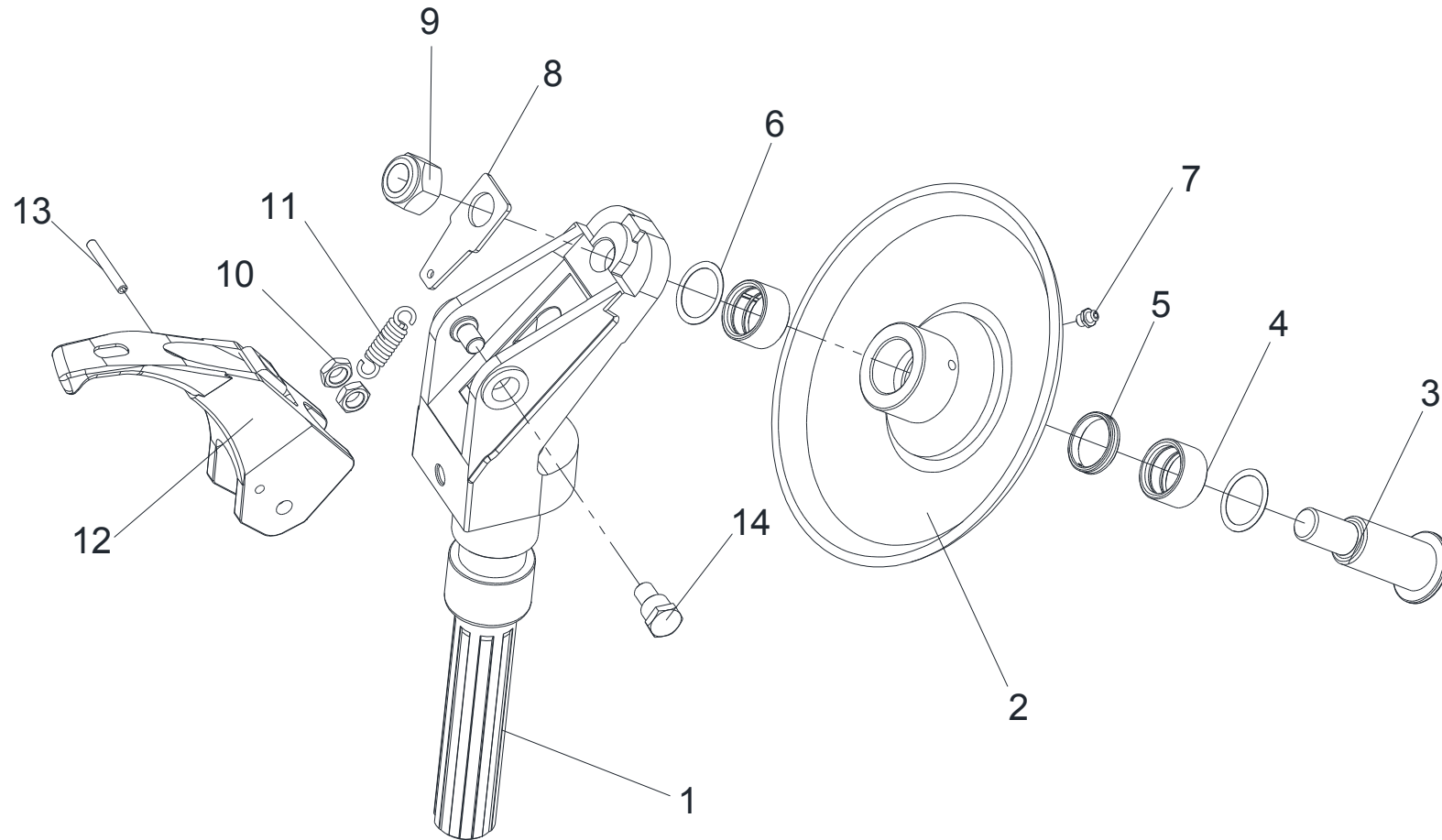

TAV.6.0

DOUBLE TOOL

ED. 11/19

ITEM	PART NO.	DESCRIPTION	QTY	REMARK
1	C56D460000	Tool support	1	
2	YC8-2410857a	Bead breaking disk	1	
3	CC-620001	Pin	1	
4	CC-620002	Bead breaking disk bush	2	
5	CC-620003	Spacer	1	
6	YC8-4396915	Steel shim	2	
7	0215020	Greaser 10X1	1	
8	CC-620004	Spring connection	1	
9	0204011	Self-locking nut M27	1	
10	0204014	Nut M16X1.5	2	
11	CC-620005	Spring	1	
12	C56D402100	Long mounting tool	1	
13	0213037	Pin	1	
14	C56D400023	Shaft	2	

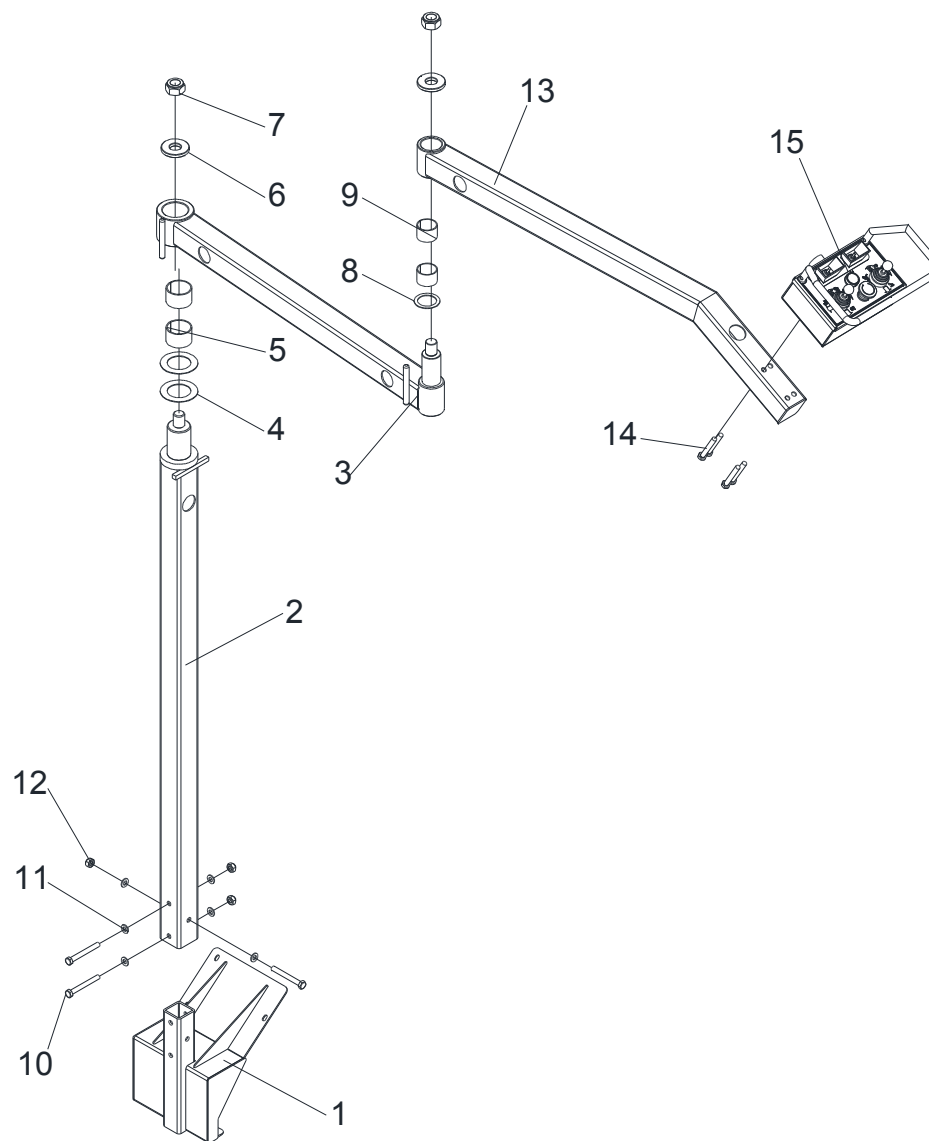

TAV.7.0

ROTATION CONTROL UNIT

ED. 11/19

ITEM	PART NO.	DESCRIPTION	QTY	REMARK
1	C56D181000	Base	1	
2	C56D182000	Post	1	
3	C60A183000	Arm 1	1	
4	C60A180001	Washer	2	
5	0210096	Bush SF-1 5035	2	
6	C60A180002	Washer	2	
7	0204039	Nut M24X2	2	
8	C60A180003	Washer	1	
9	0210030	Bush SF-1 4030	2	
10	0201054	Screw M10X85	3	
11	0205011	Washer D.10 - GB/T97.1	6	
12	0204005	Self-locking nut M10	3	
13	C60A184000	Arm 2	1	
14	0201191	Screw M10X70	4	
15	C56DD12000	Mobile control unit	1	

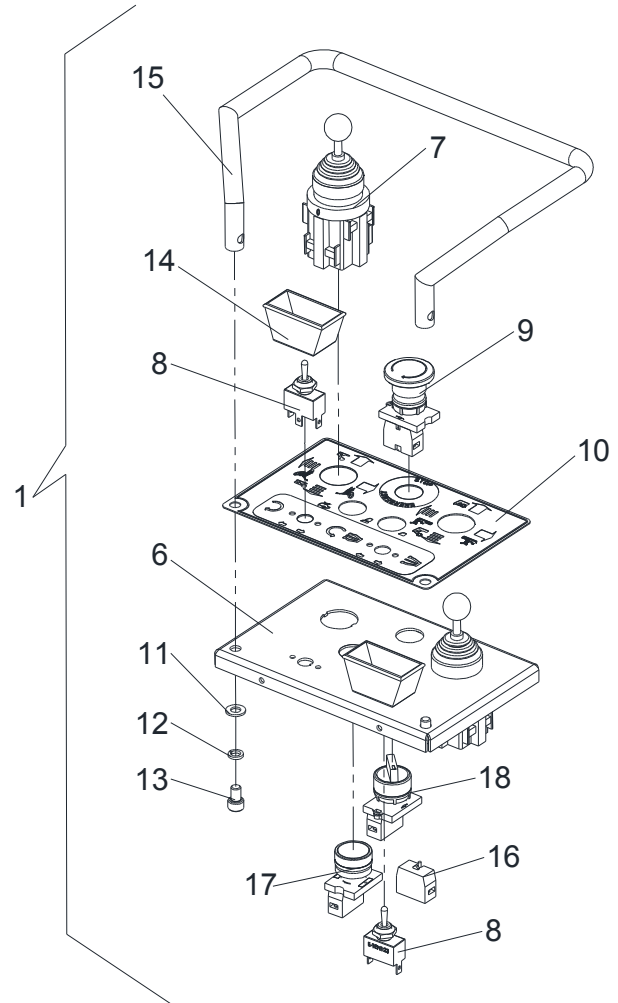
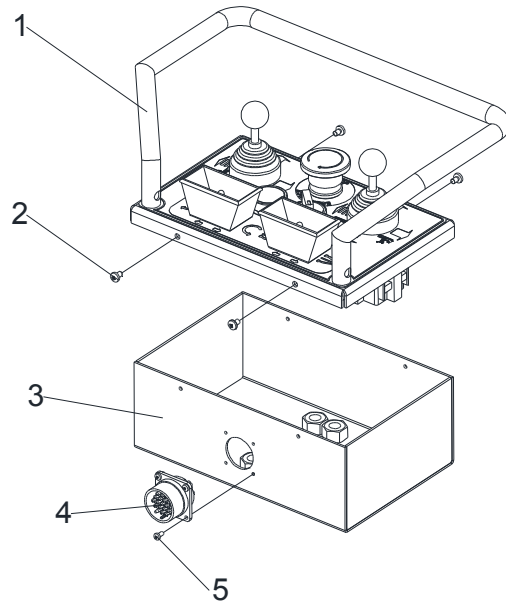

TAV.7.15	MOBILE CONTROL UNIT	ED. 11/19
----------	---------------------	-----------

ITEM	PART NO.	DESCRIPTION	QTY	REMARK
1	C56DD12400	Control unit	1	
2	0206019	Screw M4X6	4	
3	C56DD12110	Box	1	
4	0508421	Cable connector	1	
5	0206009	Screw M3X6	4	
6	C56DD12003	Control panel	1	
7	0505045	Manipulator	2	
8	0505016	Switch123	2	
9	0502066	Emergency switch	1	
10	C56DD12401	Control decal	1	
11	0205008	Washer D.8	2	
12	0208006	Spring washer D.8	2	
13	0202043	Screw M8X12	2	
14	C56BD12002	Switch protection	2	
15	C56BD12200	Handle	1	
16	0502039	Contact	1	
17	0502024	Pushbutton LAY37T-10	1	
18	0502004	MAIN/JACK selector	1	

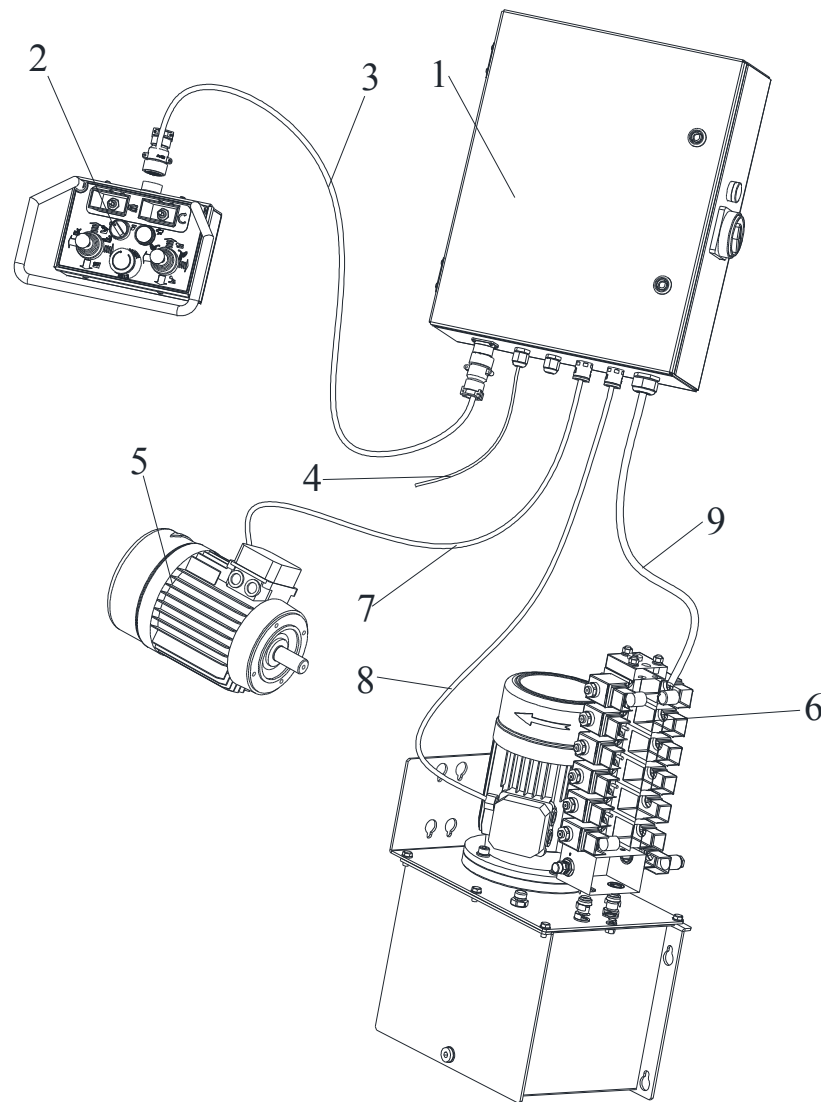

TAV.8.0	ELECTRIC CABLE	ED. 11/19
---------	----------------	-----------

ITEM	PART NO.	DESCRIPTION	QTY	REMARK
1	C56DD11000	Electric unit	1	
2	C56DD12000	Mobile control unit	1	
3	C56DD10005	Electric cable for Mobile control unit	1	
4	0506002	Electric cable for the power supply	1	
5	0509123	Double speed motor 400V/3PH/50HZ 2.6KW/3.2KW	1	
6	C56DY10000	Hydraulic power unit	1	
7	C56DD10006	Electric cable for the chuck motor	1	
8	C56DD10007	Electric cable for power unit motor	1	
9	C56DD10008	Electric cable for the valves	1	

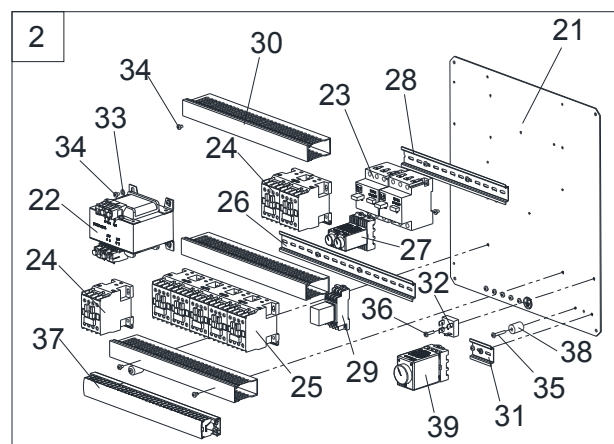
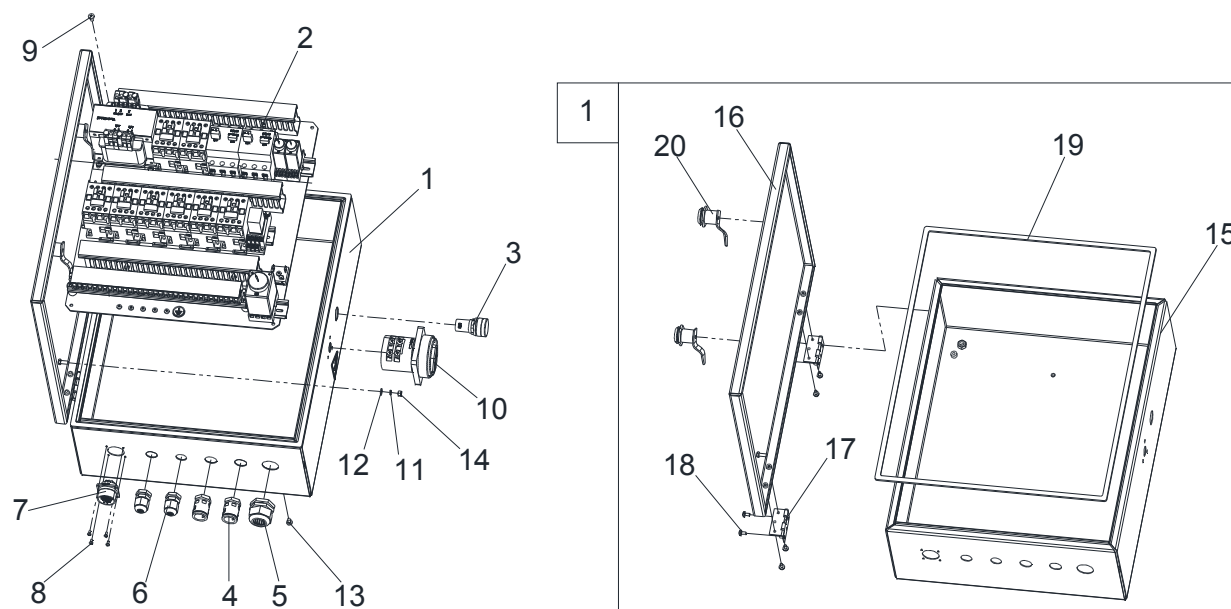

TAV.9.0	ELECTRIC UNIT	ED. 11/19
---------	---------------	-----------

ITEM	PART NO.	DESCRIPTION	QTY	REMARK
1	C56DD11400	Control box	1	
2	C56DD11100	Electric unit	1	
3	0502023	Pilot lamp AC24V	1	
4	0508303	Hose union M20	2	
5	0508012	Cable holder	1	
6	0508252	Cable relief	2	
7	0508421	Cable connector	1	
8	0206009	Screw M3X6	4	
9	0206024	Screw M5X10	4	
10	0505022	Power switch	1	
11	0208003	Spring washer D.5	2	
12	0205004	Washer D.5	2	
13	0206030	Screw M5X8	1	
14	0203003	Nut M5	1	
15	C56DD11410	Back cover	1	
16	C56DD11420	Front cover	1	
17	0509004	Hinge	2	
18	0290003	Screw M4X8	8	
19	C60AD11401	Seal	1	
20	0590007	Handle	2	
21	C56DD11111	Support	1	
22	0503075	Transformer 150VA 220/380V/29V-25V	1	
23	0501019	Breaker DZ108-20/10-16A	2	
24	0501004	Contactor 1801 AC24V	6	
25	0501002	Contactor 1210 AC24V	2	
26	0508330	Guide DZ47 L=320mm	1	
27	0501092	Timer relay	2	

28	0508330	Guide DZ47 L=250mm	1
29	0501012	Intermediate relay DC24V	1
30	0690078	Wire slot	3
31	0508330	Guide DZ47 L=50mm	1
32	0508006	Rectifier 3510	1
33	0205002	Washer D.4 - GB/T97.1	4
34	0206019	Screw M4X6	22
35	0206017	Screw M4X25	2
36	0206015	Screw M4X16	1
37	0507484	Wiring terminal	1
38	3054500400	Pin	2
39	0501018	Timer relay	1

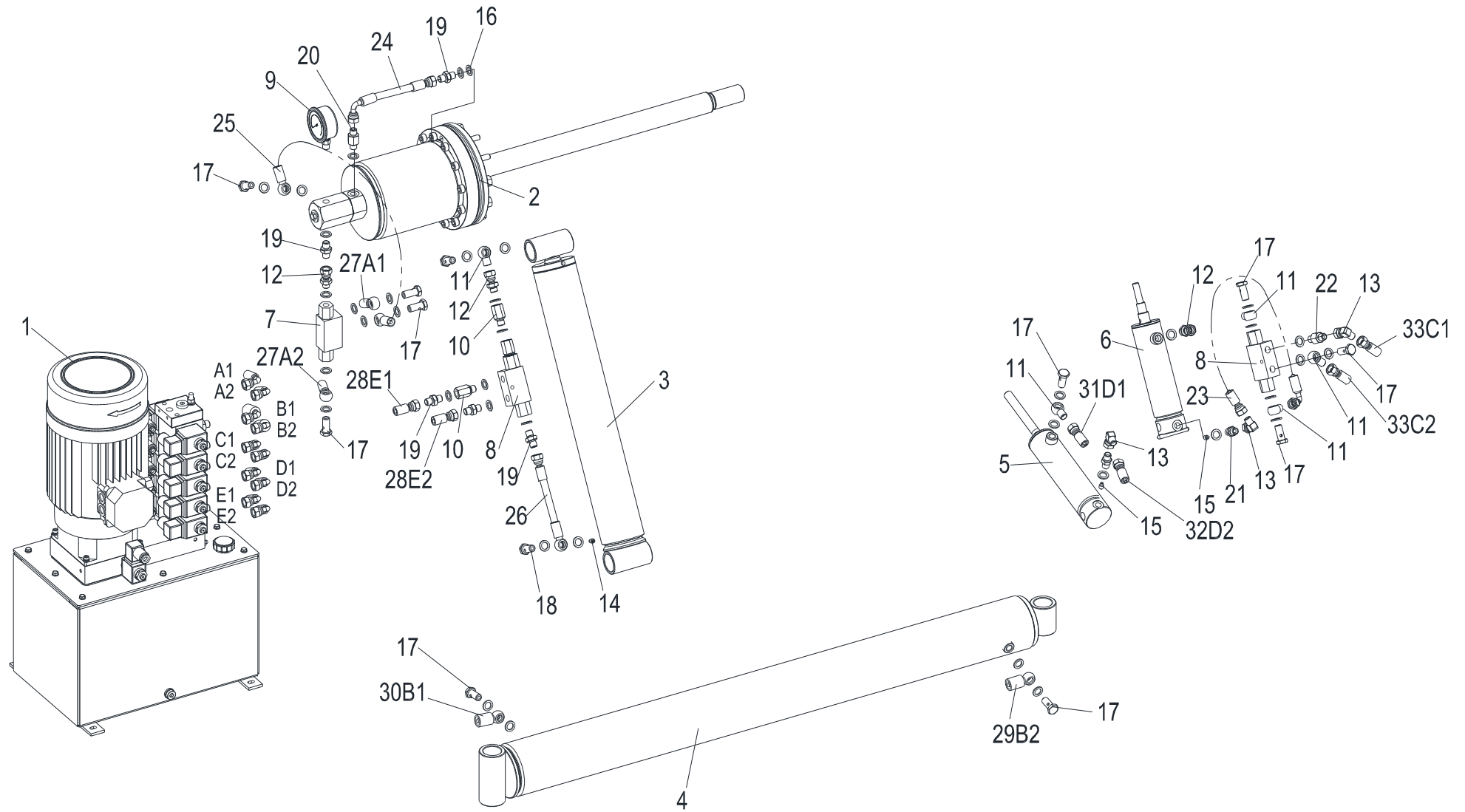

ITEM	PART NO.	DESCRIPTION	QTY	REMARK
1	C56DY10000	Hydraulic power unit	1	
2	YC8-140-0	Chuck cylinder	1	
3	C56BY20000	Chuck arm cylinder	1	
4	C56DY90000	Carriage Cylinder	1	
5	C56DY54000	Tool hooking cylinder	1	
6	C56DY45000	Rotation cylinder	1	
7	0307020	Stop valve	1	
8	0307042	Stop valve BP25000000	2	
9	0305056	Pressure gauge 250bar	1	
10	0303127	Ferrule	3	
11	0303030	Rotation union 1/4	5	
12	0303042	Reducer union 1/4	3	
13	0303073	90° union 1/4	3	
14	BZ-GZ-002	Special screw M8X12	1	
15	BZ-GZ-003	Special screw M8X12	2	
16	0313001	Washer 1/4	41	
17	0303027	Banjo bolt	11	
18	BZ-720B-0401	Special screw	1	
19	0303065	Union 1/4	5	
20	0303062	Union 1B-04-T2	1	
21	BZ-1B-0401	Union 1B-04	2	
22	0303061	Union 1B-04-T1	1	
23	ZW400	Hydraulic hose L=400	1	
24	ZW170	Hydraulic hose L=170	1	
25	JJ410	Hydraulic hose L=410	1	
26	ZJ240	Hydraulic hose L=240	1	
27	WJ1960	Hydraulic hose L=1960	2	

28	ZW400	Hydraulic hose L=400	2
29	WJ3320 (04-05)	Hydraulic hose L=3320	1
30	WJ2250 (04-05)	Hydraulic hose L=2250	1
31	ZW5200	Hydraulic hose L=5200	1
32	ZW5360	Hydraulic hose L=5360	1
33	ZW5280	Hydraulic hose L=5280	2

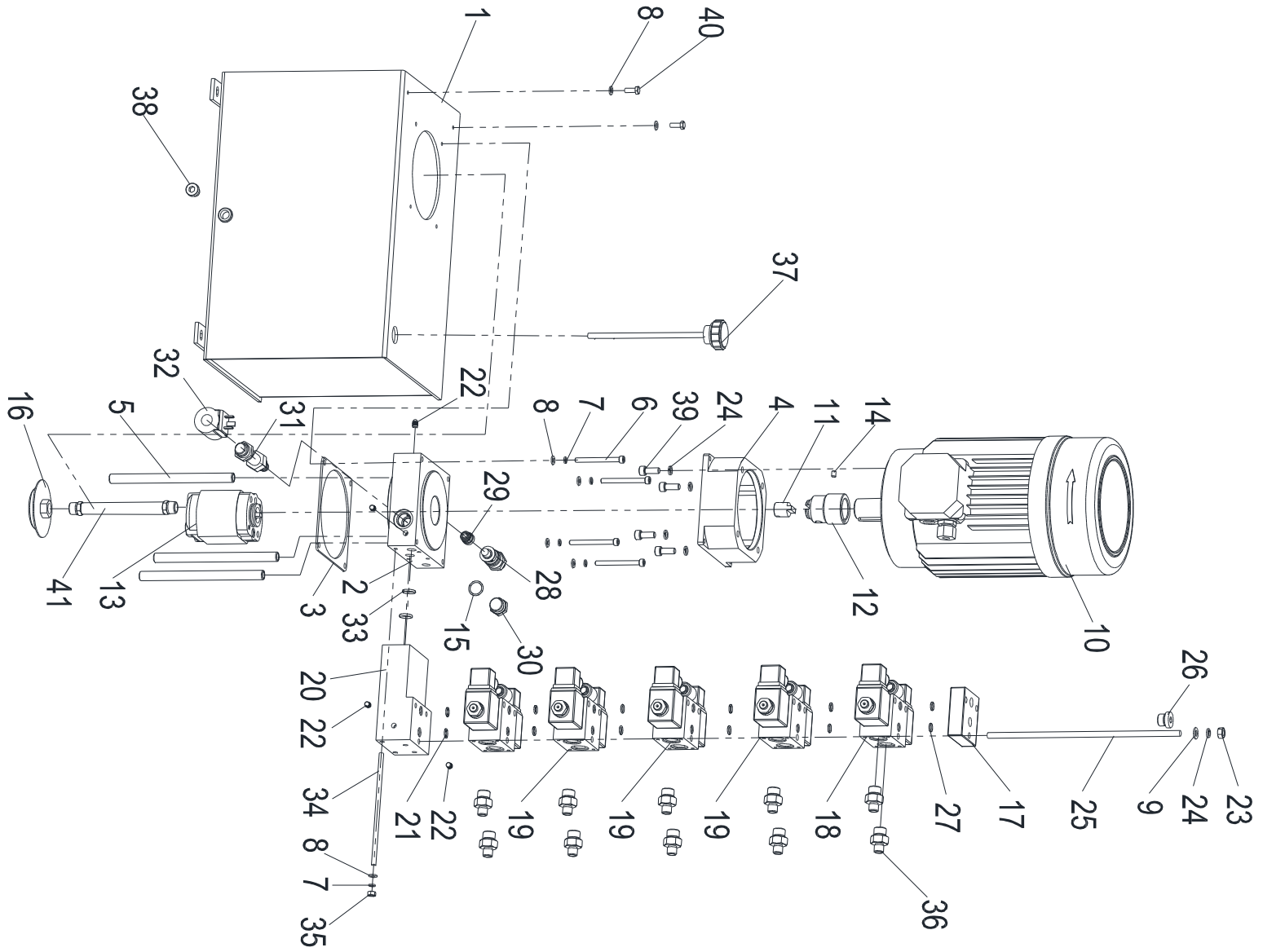

TAV.10.1	HYDRAULIC POWER UNIT	ED. 11/19
----------	----------------------	-----------

ITEM	PART NO.	DESCRIPTION	QTY	REMARK
1	C56DY12000	Oil tank	1	
2	BZ-ZB-W2	Manifold	1	
3	BZ-F-01	Gasket	1	
4	BZ-DJ-2B	Motor flange	1	
5	BZ-NG14X180	Oil return pipe	3	
6	0202036	Screw M6X65 - GB/T70.1	4	
7	0208005	Spring washer D.6 - GB/T93	8	
8	0205006	Washer D.6 - GB/T97.1	10	
9	0205008	Washer D.8 - GB/T97.1	3	
10	0509220	Motor 400V/50Hz/3ph 4.0kW	1	
11	BZ-BJ25	Pump joint	1	
12	BZ-ZT28	Motor joint	1	
13	0301025	Gear pump 7.0CC	1	
14	0209042	Screw M6X8 - GB/T80	1	
15	0309054	O-ring 17X2	1	
16	0305110	Oil filter	1	
17	0307108	Cover	1	
18	0307097	Modular directional valve 24V DC	1	
19	0307096	Modular directional valve 24V DC	4	
20	BZ-W-YC1	Interface Block	1	
21	0309014	O-ring 13X1.9	2	
22	0305001	Plug ZBJ22 007-QD07	4	
23	0203029	Nut M8	3	
24	0208006	Spring washer D.8 - GB/T93	7	
25	0213078	Lug M8X270	3	
26	0305018	Plug 4BN-06WD G3/8	1	
27	0309120	O-ring 8.5X1.80	10	

TAV.10.1	HYDRAULIC POWER UNIT	ED. 11/19
----------	----------------------	-----------

28	0307128	Pressure overload valve	1
29	0307067	Non return valve GDF-06-07-00	1
30	BZ-SD-01	Plug	1
31	0307135	Down valves	1
32	0307132	Electromagnet DC24V	1
33	0309019	O-ring 18X2.4 - GB1235	2
34	0213032	Double-screw bolt M6X150	4
35	0203035	Nut M6	4
36	0303048	Union	10
37	0305025	Oil level plug 3/4	1
38	0305016	Plug 1/4	1
39	0202045	Screw M8X20 - GB/T70.1	4
40	0201013	Screw M6X16 - GB/T5783	2
41	BZ-NG18X155	Oil suction pipe	1

ACCESSORIES

ED. 11/19

ITEM	PART NO.	DESCRIPTION	QTY	REMARK
1	DB-12T	Long bead lifting lever	1	
2	DB-11	Pliers	1	
3	0511040	Short tire lever 24"	1	
4	C56D100400	Clamp protection kit Art	4	
5	C56D100200	Clamping extension kit Art.	4	
6	C56D100401	Clamp protection	1	
7	YC8-F100102	Plastic insert 1	1	
8	0309072	O-ring 12X2.4	3	
9	YC8-F100103	Plastic insert 2	1	
10	YC8-F100104	Plastic insert 3	1	
11	YC8-F100105	Special screw	1	
12	C56D100201	Clamping extension	1	
13	CC-510101	Clamp	1	
14	0202062	Screw M10X30 - GB/T70.1	2	
15	0209085	Screw M12X30 - GB/T79	2	